



WinnForum CBRS Certificate Policy Specification

Document WINNF-17-S-0022

Version V1.0.0

24 April 2017



TERMS, CONDITIONS & NOTICES

This document has been prepared by the SSC WG5 Certificate Authority Task Group to assist The Software Defined Radio Forum Inc. (or its successors or assigns, hereafter “the Forum”). It may be amended or withdrawn at a later time and it is not binding on any member of the Forum or of the SSC WG5 Certificate Authority Task Group.

Contributors to this document that have submitted copyrighted materials (the Submission) to the Forum for use in this document retain copyright ownership of their original work, while at the same time granting the Forum a non-exclusive, irrevocable, worldwide, perpetual, royalty-free license under the Submitter’s copyrights in the Submission to reproduce, distribute, publish, display, perform, and create derivative works of the Submission based on that original work for the purpose of developing this document under the Forum's own copyright.

Permission is granted to the Forum’s participants to copy any portion of this document for legitimate purposes of the Forum. Copying for monetary gain or for other non-Forum related purposes is prohibited.

THIS DOCUMENT IS BEING OFFERED WITHOUT ANY WARRANTY WHATSOEVER, AND IN PARTICULAR, ANY WARRANTY OF NON-INFRINGEMENT IS EXPRESSLY DISCLAIMED. ANY USE OF THIS SPECIFICATION SHALL BE MADE ENTIRELY AT THE IMPLEMENTER'S OWN RISK, AND NEITHER THE FORUM, NOR ANY OF ITS MEMBERS OR SUBMITTERS, SHALL HAVE ANY LIABILITY WHATSOEVER TO ANY IMPLEMENTER OR THIRD PARTY FOR ANY DAMAGES OF ANY NATURE WHATSOEVER, DIRECTLY OR INDIRECTLY, ARISING FROM THE USE OF THIS DOCUMENT.

Recipients of this document are requested to submit, with their comments, notification of any relevant patent claims or other intellectual property rights of which they may be aware that might be infringed by any implementation of the specification set forth in this document, and to provide supporting documentation.

This document was developed following the Forum's policy on restricted or controlled information (Policy 009) to ensure that that the document can be shared openly with other member organizations around the world. Additional Information on this policy can be found here: http://www.wirelessinnovation.org/page/Policies_and_Procedures

Although this document contains no restricted or controlled information, the specific implementation of concepts contain herein may be controlled under the laws of the country of origin for that implementation. Readers are encouraged, therefore, to consult with a cognizant authority prior to any further development.

Wireless Innovation Forum TM and SDR Forum TM are trademarks of the Software Defined Radio Forum Inc.

Table of Contents

TERMS, CONDITIONS & NOTICES	i
1 Introduction	1
1.1 Overview	1
1.1.1 Certificate Policy (CP)	1
1.1.2 Key Words for Requirements	1
1.1.3 Role of the CP	1
1.1.4 Assurance level	2
1.2 Document Name and Identification	2
1.3 PKI Participants	3
1.1.1 WinnForum	4
1.1.2 Certification Authorities	4
1.1.3 Registration Authorities	5
1.1.4 Subscribers	5
1.1.5 Relying Parties	5
1.1.6 Other Participants	6
1.4 Certificate Usage	6
1.4.1 Appropriate Certificate Uses	6
1.4.2 Prohibited Certificate Uses	6
1.5 Policy Administration	6
1.5.1 Organization Administering the Document	6
1.5.2 Contact Person	6
1.5.3 Person Determining CPS Suitability for the Policy	6
1.5.4 CPS Approval Procedures	6
1.5.5 Validation Procedures	7
1.6 Definitions and Acronyms	10
2 Introduction	10
2.1 Repositories	10
2.2 Publication of Certification Information	10
2.3 Time or Frequency of Publication	10
2.4 Access Controls on Repositories	10
3 Identification and Authentication	11
3.1 Naming	11
3.1.1 Types of Names	11
3.1.2 Need for Names to be Meaningful	11
3.1.3 Anonymity or Pseudonymity of Subscribers	11
3.1.4 Rules for Interpreting Various Name Forms	11
3.1.5 Uniqueness of Names	11
3.1.6 Recognition, Authentication, and Role of Trademarks	11
3.2 Initial Identity Validation	12
3.2.1 Method to Prove Possession of Private Key	12
3.2.2 Authentication of Organization Identity	12
3.2.3 Authentication of Individual Identity	12
3.2.4 Non-verified Subscriber Information	12
3.2.5 Validation of Authority	13

3.3	Identification and Authentication for Re-key Requests.....	13
3.3.1	Identification and Authentication for Routine re-key.....	13
3.3.2	Identification and Authentication for Re-key After Revocation.....	13
3.4	Identification and Authentication for Revocation Request.....	13
4	Certificate Life-Cycle operational requirements.....	13
4.1	Certificate Application.....	13
4.1.1	Who Can Submit a Certificate Application	14
4.1.2	Enrollment Process and Responsibilities	14
4.2	Certificate Application Processing	14
4.2.1	Performing Identification and Authentication Functions	14
4.2.2	Approval or Rejection of Certificate Applications	14
4.2.3	Time to Process Certificate Applications	15
4.3	Certificate Issuance.....	15
4.3.1	CA Actions During Certificate Issuance.....	15
4.3.2	Notification to Subscriber by the CA of Issuance of Certificate	15
4.4	Certificate Acceptance	15
4.4.1	Conduct Constituting Certificate Acceptance.....	15
4.4.2	Publication of the Certificate by the CA.....	15
4.4.3	Notification of Certificate Issuance by the CA to Other Entities	16
4.5	Key Pair and Certificate Usage.....	16
4.5.1	Subscriber Private Key and Certificate Usage.....	16
4.5.2	Relying Party Public Key and Certificate Usage.....	16
4.6	Certificate Renewal.....	16
4.6.1	Circumstance for Certificate Renewal	16
4.6.2	Who may Request Renewal	17
4.6.3	Processing Certificate Renewal Requests	17
4.6.4	Notification of New Certificate Issuance to Subscriber	17
4.6.5	Conduct Constituting Acceptance of a Renewal Certificate.....	17
4.6.6	Publication of the Renewal Certificate by the CA.....	17
4.6.7	Notification of Certificate Issuance by the CA to Other Entities	17
4.7	Certificate Re-key	17
4.7.1	Circumstance for Certificate Re-key	17
4.7.2	Who May Request Certification of a New Public Key.....	17
4.7.3	Processing Certificate Re-keying Requests	18
4.7.4	Notification of New Certificate Issuance to Subscriber	18
4.7.5	Conduct Constituting Acceptance of a Re-keyed Certificate	18
4.7.6	Publication of the Re-keyed Certificate by the CA	18
4.7.7	Notification of Certificate Issuance by the CA to Other Entities	18
4.8	Certificate Modification.....	18
4.8.1	Circumstance for Certificate Modification	18
4.8.2	Who May Request Certificate Modification.....	19
4.8.3	Processing Certificate Modification Requests	19
4.8.4	Notification of New Certificate Issuance to Subscriber	19
4.8.5	Conduct Constituting Acceptance of Modified Certificate	19
4.8.6	Publication of the Modified Certificate by the CA.....	19
4.8.7	Notification of Certificate Issuance by the CA to Other Entities	19

4.9	Subscriber Certificate Revocation and Suspension	19
4.9.1	Circumstances for Revocation	19
4.9.2	Who can Request Revocation	20
4.9.3	Procedure for Revocation Request.....	20
4.9.4	Revocation Request Grace Period	21
4.9.5	Time Within Which CA Shall Process the Revocation Request	21
4.9.6	Revocation Checking Requirement for Relying Parties	21
4.9.7	CRL Issuance Frequency	21
4.9.8	Maximum Latency for CRLs	22
4.9.9	On-line Revocation/Status Checking Availability	22
4.9.10	On-line Revocation Checking Requirements.....	22
4.9.11	Other Forms of Revocation Advertisements Available	22
4.9.12	Special Requirements Regarding Key Compromise.....	22
4.9.13	Circumstances for Suspension	22
4.9.14	Who can Request Suspension	22
4.9.15	Procedure for Suspension Request.....	23
4.9.16	Limits on Suspension Period	23
4.10	Certificate Status Services	23
4.10.1	Operational Characteristics	23
4.10.2	Service Availability	23
4.10.3	Optional Features	23
4.11	End of Subscription.....	23
4.12	Key Escrow and Recovery	23
4.12.1	Key Escrow and Recovery Policy and Practices	23
4.12.2	Session Key Encapsulation and Recovery Policy and Practices	23
5	Facility, Management, and Operational Controls	23
5.1	Physical Controls	23
5.1.1	Site Location and Construction.....	24
5.1.2	Physical Access.....	24
5.1.3	Power and Air Conditioning	26
5.1.4	Water Exposures	26
5.1.5	Fire Prevention and Protection.....	26
5.1.6	Media Storage	26
5.1.7	Waste Disposal.....	26
5.1.8	Off-site Backup.....	26
5.2	Procedural Controls	27
5.2.1	Trusted Roles	27
5.2.2	Number of Persons Required per Task	27
5.2.3	Identification and Authentication for Each Role	28
5.2.4	Roles Requiring Separation of Duties.....	28
5.3	Personnel Controls	29
5.3.1	Qualifications, Experience, and Clearance Requirements	29
5.3.2	Background Check Procedures	29
5.3.3	Training Requirements.....	29
5.3.4	Retraining Frequency and Requirements.....	30
5.3.5	Job Rotation Frequency and Sequence	30

5.3.6	Sanctions for Unauthorized Actions	30
5.3.7	Independent Contractor Requirements	30
5.3.8	Documentation Supplied to Personnel.....	30
5.4	Audit Logging Procedures	31
5.4.1	Types of Events Recorded	31
5.4.2	Frequency of Processing Log.....	32
5.4.3	Retention Period for Audit Log	32
5.4.4	Protection of Audit Log	32
5.4.5	Audit Log Backup Procedures	33
5.4.6	Audit Collection System (Internal vs. External).....	33
5.4.7	Notification to Event-Causing Subject	33
5.4.8	Vulnerability Assessments.....	33
5.5	Records Archival	33
5.5.1	Types of Records Archived	33
5.5.2	Retention Period for Archive	34
5.5.3	Protection of Archive	34
5.5.4	Archive Backup Procedures.....	34
5.5.5	Requirements for Time-Stamping of Records	35
5.5.6	Archive Collection System (Internal or External)	35
5.5.7	Procedures to Obtain and Verify Archive Information.....	35
5.6	Key Changeover.....	35
5.7	Compromise and disaster recovery	35
5.7.1	Incident and Compromise Handling Procedures	35
5.7.2	Computing Resources, Software, and/or Data are Corrupted.....	35
5.7.3	Entity Private Key Compromise Procedures	36
5.7.4	Business continuity capabilities after a disaster.....	36
5.8	CA or RA Termination	37
6	Technical Security Controls	37
6.1	Key Pair Generation and Installation	37
6.1.1	Key Pair Generation.....	37
6.1.2	Private Key Delivery to Subscriber	38
6.1.3	Public Key Delivery to Certificate Issuer	38
6.1.4	CA Public Key Delivery to Relying Parties	39
6.1.5	Public Key Parameters Generation and Quality Checking.....	39
6.1.6	Key Usage Purposes (as per X.509 v3 Key Usage Field).....	39
6.2	Private Key Protection and Cryptographic Module Engineering Controls	40
6.2.1	Cryptographic Module Standards and Controls.....	40
6.2.2	Private Key (m out of n) Multi-Person Control	41
6.2.3	Private Key Escrow.....	41
6.2.4	Private Key Backup	41
6.2.5	Private Key Archival.....	42
6.2.6	Private Key Transfer into or from a Cryptographic Module	42
6.2.7	Private Key Storage on Cryptographic Module.....	42
6.2.8	Method of Activating Private Key	43
6.2.9	Method of Deactivating Private Key	43
6.2.10	Method of Destroying Private Key	44

6.2.11	Cryptographic Module Rating	44
6.3	Other Aspects of Key Pair Management	44
6.3.1	Public Key Archival.....	44
6.3.2	Certificate Operational Periods and Key Pair Usage Periods.....	45
6.4	Activation data.....	45
6.4.1	Activation Data Generation and Installation.....	45
6.4.2	Activation Data Protection.....	45
6.4.3	Other Aspects of Activation Data	46
6.5	Computer security controls	46
6.5.1	Specific Computer Security Technical Requirements	46
6.5.2	Computer Security Rating.....	47
6.6	Life Cycle Technical Controls	48
6.6.1	System Development Controls	48
6.6.2	Security Management Controls.....	48
6.6.3	Life Cycle Security Controls	48
6.7	Network Security Controls	48
6.8	Time-Stamping	49
7	Certificate, CRL, and OCSP Profiles.....	49
7.1	Certificate Profile.....	49
7.2	CRL Profile.....	57
7.2.1	Version Number(s).....	57
7.2.2	CRL and CRL entry extensions	57
7.3	OCSP Profile.....	57
7.3.1	Version Number(s).....	58
7.3.2	OCSP Extensions	58
8	Compliance Audit and Other Assessments	58
8.1	Frequency or Circumstances of Assessment.....	58
8.2	Identity/Qualifications of Assessor.....	58
8.3	Assessor's Relationship to Assessed Entity	58
8.4	Topics Covered by Assessment	59
1.2	Actions Taken as a Result of Deficiency	59
8.5	Communication of Results.....	60
9	Other Business and Legal Matters	60
9.1	Fees	60
9.1.1	Certificate Issuance or Renewal Fees	60
9.1.2	Certificate Access Fees	60
9.1.3	Revocation or Status Information Access Fees	60
9.1.4	Fees for Other Services	60
9.1.5	Refund Policy.....	61
9.2	Financial Responsibility.....	61
9.2.1	Insurance Coverage.....	61
9.2.2	Other Assets	61
9.2.3	Insurance or Warranty Coverage for End-Entities.....	61
9.3	Confidentiality of business information.....	61
9.3.1	Scope of Confidential Information	61
9.3.2	Information not Within the Scope of Confidential Information	61

9.3.3	Responsibility to Protect Confidential Information	61
9.4	Privacy of Personal Information	62
9.4.1	Privacy Plan	62
9.4.2	Information Treated as Private.....	62
9.4.3	Information not Deemed Private.....	62
9.4.4	Responsibility to Protect Private Information.....	62
9.4.5	Notice and Consent to Use Private Information	62
9.4.6	Disclosure Pursuant to Judicial or Administrative Process	62
9.4.7	Other Information Disclosure Circumstances.....	62
9.5	Intellectual Property Rights	62
9.6	Representations and Warranties.....	63
9.6.1	CA Representations and Warranties	63
9.6.2	RA Representations and Warranties	64
9.6.3	Subscriber representations and warranties.....	64
9.6.4	Relying Party Representations and Warranties.....	65
9.6.5	Representations and Warranties of Other Participants	65
9.7	Disclaimers of warranties	65
9.8	Limitations of liability	65
9.9	Indemnities.....	65
9.10	Term and termination.....	65
9.10.1	Term.....	65
9.10.2	Termination.....	66
9.10.3	Effect of termination and survival	66
9.11	Individual notices and communications with participants.....	66
9.12	Amendments	66
9.12.1	Procedure for Amendment.....	66
9.12.2	Notification Mechanism and Period	66
9.12.3	Circumstances Under Which OID Shall be Changed.....	66
9.13	Dispute Resolution Provisions.....	66
9.14	Governing Law	67
9.15	Compliance with Applicable Law	67
9.16	Miscellaneous provisions.....	67
9.16.1	Entire Agreement.....	67
9.16.2	Assignment	67
9.16.3	Severability	67
9.16.4	Enforcement (Attorneys' fees and waiver of rights)	67
9.16.5	Force Majeure	68
9.17	Other Provisions.....	68
10	References	68
11	Glossary	68
12	Abbreviations and Acronyms.....	71

List of Figures

Figure 1 CBRS PKI Hierarchy	3
-----------------------------------	---

List of Tables

Table 1 WinnForum OID Arcs	2
Table 2: keyUsage Extension for all CA certificates.....	39
Table 3: keyUsage Extension for Subscriber Certificates with RSA Public Keys	40
Table 4: RSA Root CA Certificate Profile	49
Table 5: RSA Sub-CA Certificate Profile.....	50
Table 6: RSA Subscriber Certificate Profile.....	51
Table 7: ECC Root CA Certificate Profile	53
Table 8: ECC Sub-CA Certificate Profile.....	54
Table 9: ECC Subscriber Certificate Profile.....	55
Table 10: CRL Profile Basic Fields	57
Table 11: Document Change Notice (DCN).....	73

WinnForum CBRS Certificate Policy

1 Introduction

1.1 Overview

This document defines the certificate policy for the Public Key Infrastructure (PKI) which governs communications within the Citizens Broadband Radio Service (CBRS) ecosystem and provides authentication and authorization for messages exchanged within the SAS ecosystem as part of the protocols described in the SAS-CBSD Technical Report and the SAS-SAS Technical Report.

CBRS certificates are the basis for a number of security services including authentication, confidentiality, integrity, and non-repudiation. In order for a certificate to be in compliance with CBRS specifications, it shall comply with this Certificate Policy. This Policy assumes that the reader is generally familiar with Digital Signatures, PKIs and CBRS specifications.

1.1.1 Certificate Policy (CP)

This Certificate Policy is consistent with the *Internet X.509 PKI Certificate Policy and Certification Practices Framework* [RFC 3647]. It governs the certificate PKI operations of components by all individuals and entities within the CBRS PKI (collectively, “PKI Participants”). It provides the minimum requirements that PKI Participants are required to meet when issuing and managing Certification Authorities (CAs), digital certificates, and private keys related to the CBRS. In addition, it informs potential Relying Parties about what they need to know prior to relying on issued certificates.

This CP also defines the terms and conditions under which the CAs SHALL operate to issue certificates. Where “operate” includes certificate management (i.e., approve, issue, and revoke) of issued certificates and “issue” in this context refers to the process of digitally signing with the private key associated with its authority certificate a structured digital object conforming to the X.509, version 3 certificate format.

1.1.2 Key Words for Requirements

The following terms are used within this document and should be interpreted as described in [RFC-2119](#):

- SHALL is a mandatory requirement (negative is SHALL NOT)
- SHOULD is recommended requirement/best practice (negative is SHOULD NOT)
- MAY is an optional requirement, i.e., something that is allowed (negative is NEED NOT)

1.1.3 Role of the CP

The CP describes the overall business, legal, and technical infrastructure of the CBRS PKI. More specifically, it describes, among other things:

- Appropriate applications for, and the assurance levels associated with the PKI certificates
- Obligations of CAs

- Minimum requirements for audit and related security and practices reviews
- Methods to confirm the identity of Certificate Applicants
- Operational procedures for certificate lifecycle services: certificate application, issuance, acceptance, revocation, and renewal
- Operational security procedures for audit logging, records retention, and disaster recovery
- Physical, personnel, key management, and logical security
- Certificate Profile and Certificate Revocation List content

The CP is an integral part of the CBRS PKI documentation and sets the minimum standards for governing, administrating and operating the PKI. Ancillary security and operational documents may supplement the CP in setting more detailed requirements. Additionally, each CBRS PKI CA is governed by a Certification Practice Statement(s) (CPS), which describes how the applicable CP requirements are met by that particular CA. CAs operating in the CBRS PKI shall draft, implement, and maintain a CPS.

1.1.4 Assurance level

CBRS digital certificates provide assurances that the certificate Subscriber’s distinguished name is unique and unambiguous within the CBRS CA’s domain, and the identity of the Subscriber’s organization is based on a comparison of information submitted by the Subscriber against information in business records or databases. These certificates can be used for digital signatures, encryption, and authentication for proof of identity of components that contain CBSD certificates and are compliant with CBRS specifications and this CP.

1.2 Document Name and Identification

This document is the CBRS PKI Certificate Policy and was approved for publication on {{TBD}} by the Wireless Innovation Forum (WinnForum).

The OID for WinnForum is iso (1) identified-organization (3) dod (6) internet (1) private (4) enterprise (1) The Wireless Innovation Forum (46609). WinnForum organizes its OID arcs for the Certificates described in this CP as follows:

Table 1 WinnForum OID Arcs

Digitally Signed Object	Object Identifier (OID)
Policy Documents	1.3.6.1.4.1.46609.2
Certificates issued pursuant to CPS	1.3.6.1.4.1.46609.2.1
CBRS PKI Role OID Arc	1.3.6.1.4.1.46609.1.1
SAS	1.3.6.1.4.1.46609.1.1.1
INSTALLER	1.3.6.1.4.1.46609.1.1.2

CBSD	1.3.6.1.4.1.46609.1.1.3
OPERATOR	1.3.6.1.4.1.46609.1.1.4
CA	1.3.6.1.4.1.46609.1.1.5
PAL	1.3.6.1.4.1.46609.1.1.6

1.3 PKI Participants

The CBRS PKI is a three or four tier infrastructure with CBRS Root CAs at tier 1 that issue intermediate CA certificates (i.e., sub-CAs) at tier 2. The tier 2 sub-CAs issue compliant end-entity Subscriber certificates or CBSD OEM CA certificates at tier 3. Tier 3 sub-CAs issue compliant end-entity CBSD Subscriber certificates (see Figure 1). There are up to 6 different CA chains anchored by a CBRS Root CA: SAS Provider, Domain Proxy, Professional Installer, PAL, CBSD Mfr, and CBSD OEM. The WinnForum will make the list of approved Root CAs available to Subscribers.

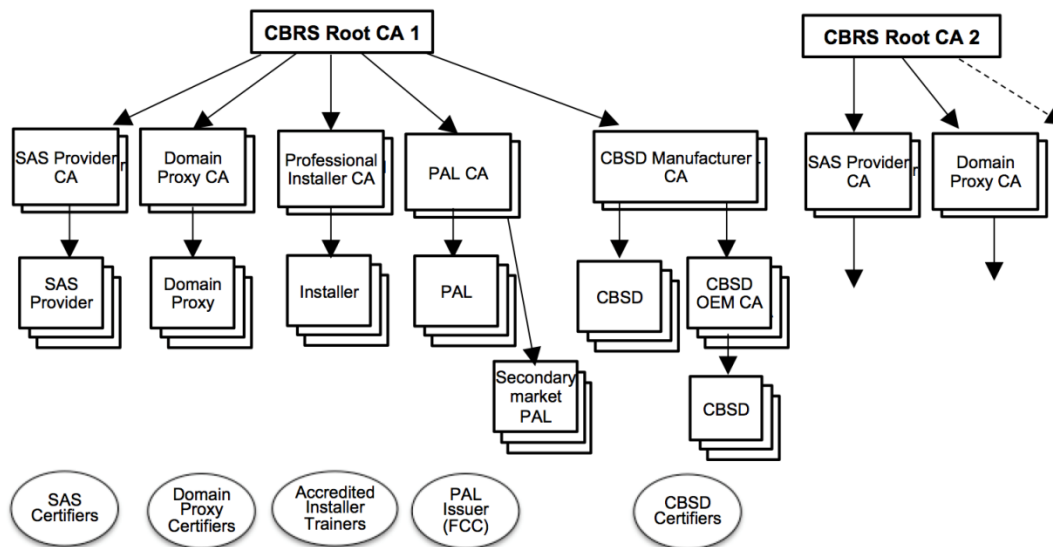

Figure 1 CBRS PKI Hierarchy

The CBRS Root CA is the apex of its Root CA Domain. The Root CA will issue the sub-CA certificates to approved CA service providers. The sub-CAs will issue certificates to authorized Subscribers, which will embed the certificates in compliant devices. . It is assumed that an Installer certificate will be installed in a device used by an authorized installer to manage/configure CBSDs

Subscribers should install all WinnForum authorized CBRS Root CA certificates in their device trust anchor stores to validate received certificates. The end-entity certificate, its private key, and all sub-CA certificates for a given CA chain should also be installed on the device. During the TLS authentication messaging exchange the end-entity and all sub-CA chain certificates should be sent to the other end point.

The following describes the relevant participant roles in the CBRS PKI.

1.1.1 WinnForum

The WinnForum and its members foster the development, adoption and compliance of the CBRS standard. The WinnForum has established the framework for the CBRS PKI and governs and oversees operation of the PKI. In particular, this CP was established under the authority of and with the approval of the WinnForum.

1.1.2 Certification Authorities

At the heart of the CBRS PKI are entities called “Certification Authorities” or “CAs.” CA is an umbrella term that refers to the collection of hardware, software, and operating personnel that create, sign, and issue public key certificates to Subscribers or other CAs. The CAs are responsible for:

- Developing and maintaining a CPS
- Issuing compliant certificates
- Delivery of certificates to its Subscribers in accordance with the CP, and other applicable documents such as the Subscriber’s Subscriber Agreement
- Revocation of Certificates
- Generation, protection, operation, and destruction of CA private keys
- CA Certificate lifecycle management ensuring that all aspects of the CA services, operations, and infrastructure related to certificates issued under this CP are performed in accordance with the requirements, representations, and warranties of this CP
- CAs act as trusted parties to facilitate the confirmation of the binding between a public key and the identity, and/or other attributes, of the “Subject” of the Certificate. In the CBSD PKI, the Subject of a CA certificate is the Subscriber (i.e., WinnForum or manufacturer) requesting the CA certificate and the Subject of a device certificate is the Subscriber (i.e., manufacturer) requesting the device certificate.

CBRS CAs fall into two categories: (1) Root CAs, which are operated by a designated CBRS Root CA service providers and issue sub-CA certificates; and (2) the sub-CAs which are operated by designated CBRS sub CA service providers and issue end-entity device certificates to Subscribers.

CAs may provide a secure method for the automated issuance of end-entity certificates from sub CAs. This could be supported onsite at a Subscriber’s manufacturing facility using CA approved hardware and software components or using a remote API. These methods shall be compliant to the requirements of this CP.

1.1.3 Registration Authorities

Registration Authorities (RAs) are entities that enter into an agreement with a Certification Authority to collect and verify each Subscriber's identity and information to be entered into the Subscriber's certificates. The RA performs its function in accordance with this CP and its approved CPS and will perform front-end functions of confirming the identity of the certificate applicant, approving or denying Certificate Applications, requesting revocation of certificates, and managing account renewals.

In order to improve the flexibility and logistics speed in the manufacturing system the manufacturer MAY implement its product certification solution in an automated fashion, without human involvement in certificate issuance. For this case the RA functionality MAY be a software and a hardware application which is technically part of the manufacturing system.

1.1.4 Subscribers

In the CBRS PKI, the Subscriber is the organization named in the Digital Certificate Subscriber Agreement (DCSA). An authorized representative of the Subscriber, acting as a Certificate Applicant, SHALL complete the certificate application process established by the RA. In response, the CA relies on the RA to confirm the identity of the Certificate Applicant and either approves or denies the application. If approved, the RA communicates to the CA, and the Subscriber can then request certificates.

The WinnForum requires that Subscribers adopt the appropriate CBRS certificate policy requirements and any additional certificate management practices to govern the Subscriber's practice for requesting certificates and handling the corresponding private keys. The Subscriber agrees to be bound by its obligations through execution of the DCSA between the Subscriber and the RA, and any other applicable agreements. This includes the case where the Subscriber has implemented an automated manufacturing process for requesting and issuing end-entity certificates for installation into devices (e.g. CBSD).

CAs, technically, are also Subscribers of certificates within a PKI, either as a Root CA issuing a self-signed Certificate to itself, or as a sub-CA. References to "Subscribers" in this CP, however, apply only to the organizations requesting device certificates, including those Subscribers who may have arranged to have a sub-CA operated onsite at their manufacturing facility.

1.1.5 Relying Parties

The Relying Party is any entity that validates the binding of a public key to the Subscriber's name in a device certificate. The Relying Party is responsible for deciding whether or how to check the validity of the certificate by checking the appropriate certificate status information. The Relying Party can use the certificate to verify the integrity of a digitally signed message, to identify the initiator of a communication, or to establish confidential communications with the holder of the certificate. For instance, a SAS can use the device certificate embedded in a CBSD device to authenticate the device requesting services from the server.

1.1.6 Other Participants

1.1.6.1 Auditors

The PKI participants operating under this CP MAY require the services of other security authorities, such as compliance auditors. The CA's CPS will identify the parties responsible for providing such services, and the mechanisms used to support these services.

1.4 Certificate Usage

This CP applies to all CBRS PKI Participants, including Subscribers and Relying Parties. This CP sets forth policies governing the use of CBRS PKI Certificates. Each Certificate is generally appropriate for use as set forth in this CP.

1.4.1 Appropriate Certificate Uses

Certificates are suitable for authentication of devices and confidentiality encryption. The use of the certificates permits message integrity checks, confidentiality of communications, and support for Non-repudiation.

1.4.2 Prohibited Certificate Uses

CBRS PKI Certificates are not designed, intended, or authorized for use or resale as control equipment in hazardous circumstances or for uses requiring fail-safe performance such as the operation of nuclear facilities, aircraft navigation systems, aircraft communication systems, air traffic control systems, or weapons control systems, where failure could lead directly to death, personal injury, or severe environmental damage.

1.5 Policy Administration

1.5.1 Organization Administering the Document

The WInnForum is responsible for all aspects of this CP.

1.5.2 Contact Person

Inquiries regarding this CP shall be directed to the WInnForum.

1.5.3 Person Determining CPS Suitability for the Policy

The WInnForum SHALL approve the CPS for each CA that issues certificates under this policy, such approval not to be unreasonably withheld.

1.5.4 CPS Approval Procedures

CAs and RAs operating under this CP are required to meet all facets of the policy. The WInnForum SHALL make the determination that a CPS complies with this policy. The CA and RA SHALL meet all requirements of an approved CPS before commencing operations.

1.5.5 Validation Procedures

This section enumerates the validation procedures a Certificate Authority (CA) shall follow before signing CBRS certificate requests. These procedures are in addition to those defined in section 3.2. All certificates signed shall follow the profiles defined section 7.

"Validation" in this context shall mean the CA's determination that a signature issuance requirement is met, the collection and retention of documentation records supporting the determination that the requirement was fulfilled by the requestor of the certificate throughout the lifetime of the certificate, and the ability of the CA to produce such records in response to a proper audit request. The validation may be processed by a Registration Authority (RA) which is authorized by the CA. In this case the CA may accept the certificate request without additional validation and the audit requirements on the validation are carried out by the RA. In addition, the CA may replace the content of static fields in the Certificate Request with predefined and prevalidated values without validating the requested values. The CA may not have connection to the manufacturing data of the equipment that needed for the certificate issuance. Automated RA at manufacturing site may perform the content validation and send the approved request to the CA. Similarly, the necessary checks for certificates issued to a human recipient (such as the proof of identity) may be processed by an RA operator.

Root of Trust Self-Signed Certificate Issuance Requirements

A CA shall sign a Self-Signed Certificate to be used as a CBRS PKI Root of Trust if and only if:

1. It is specifically requested to create that self-signed certificate by a balloted resolution of the WInnForum.
2. It has satisfied the requirements of a CBRS PKI Root-of-Trust Certificate Operator as enumerated by the WInnForum.

Sub-CA Certificate Issuance Requirements

A CA shall sign a Sub-CA request (SAS Provider CA, Domain Proxy CA, Professional Installer CA, Device Manufacturer CA) using a Root-of-Trust certificate if and only if:

1. It enters into a contractual relationship with the Sub-CA entity requiring that entity to abide by the WInnForum CBRS PKI Certificate Policy guidelines; or if the Sub-CA entity is the same as the Root-of-Trust Certificate Operator entity, it has satisfied the requirements of the CBRS PKI Root-of-Trust Certificate Operator as defined by WInnForum.
2. It validates the Sub-CA certificate attributes defined in in section 7
3. It enters into a contractual relationship with the Sub-CA entity requiring it to abide by the auditing requirements defined in section 8
4. It verifies that the technical attributes of the certificate are valid according to the Sub-CA certificate type requested. (Validity, Extended Key Usage, SAS extensions)

CBSD OEM CA Certificate Issuance Requirements

A CA shall sign a CBSD OEM CA request using a CBSD Manufacturer CA certificate if and only if:

1. It enters into a contractual relationship with the CBSD OEM CA entity requiring that entity to abide by the WInnForum CBRS PKI Certificate Policy guidelines; or if the CBSD OEM CA entity is the same as the CBSD Manufacturer CA Certificate Operator entity, it has satisfied the requirements of the CBRS PKI CBSD Manufacturer CA Certificate Operator as defined by WInnForum.
2. It validates the CBSD OEM CA certificate attributes defined in section 7
3. It enters into a contractual relationship with the CBSD OEM CA entity requiring it to abide by the auditing requirements defined in section 8.
4. [[Optionally, it validates that an FCC ID is indicated in the CBSD OEM CA certificate signing request, and that the indicated FCC ID is a valid and certified FCC ID authorized for use in the CBRS band, according to the WInnForum CBRS PKI Certificate Policy guidelines.]]

SAS Provider End Entity Certificate Issuance Guidelines

A CA shall sign a SAS Provider End Entity certificate request using a SAS Provider CA certificate if and only if:

1. It validates the SAS Provider End Entity certificate attributes defined in section 7.
2. It validates that the entity presenting the SAS Provider certificate signing request has been certified as a SAS Administrator by the FCC, and that the certificate attributes reflect this identity.
3. It validates that the entity presenting the SAS Provider certificate signing request has an FCC-certified SAS and that it has passed all related WInnForum certification tests.
4. It validates that the domain endpoints enumerated in the attributes of the certificate are under the control of the SAS Administrator.
5. It enters into a binding user agreement with the entity requesting the SAS Provider certificate to be signed according to the requirements in the WInnForum CBRS PKI Certificate Policy.

Domain Proxy End Entity Certificate Issuance Guidelines

A CA shall sign a Domain Proxy End Entity certificate request using a Domain Proxy CA certificate if and only if:

1. It validates the Domain Proxy End Entity certificate attributes enumerated in section 7.
2. It validates that the entity presenting the Domain Proxy certificate signing request has been certified as a Domain Proxy operator by the FCC, and that the certificate attributes reflect this identity.
3. It validates that the entity presenting the Domain Proxy certificate signing request is operating an FCC-certified Domain Proxy and that it has passed all WinnForum certification tests.]
4. It enters into a binding user agreement with the entity requesting the Domain Proxy certificate to be signed according to the requirements in the WinnForum CBRS PKI Certificate Policy.

Professional Installer End Entity Certificate Issuance Guidelines

A CA shall sign a Professional Installer End Entity certificate request using a Professional Installer CA certificate if and only if:

1. It validates the Professional Installer End Entity certificate attributes enumerated in section 7
2. It validates that the individual on whose behalf the Professional Installer certificate signing request has been presented is a Certified Professional Installer as vouched for by the Administrator of the CPI Training Program completed by the individual, and that the certificate attributes reflect this identity.
3. Validate the unique identifier (CPIR-ID) as presented with the CPI Accrediting Body as consistent with the identifying information in the certificate.
4. It enters into a binding user agreement with the entity requesting the Professional Installer certificate to be signed according to the requirements in the WinnForum CBRS PKI Certificate Policy.

CBSD End Entity Certificate Issuance Guidelines

A CA shall sign a CBSD End Entity certificate request using a CBSD Manufacturer CA or a CBSD OEM CA certificate if and only if:

It validates the CBSD End Entity certificate attributes defined in section 7 including the FCC ID in the device identifier. The format of the device identifier serial number may optionally be validated.

It validates that the entity submitting the CBSD End Entity certificate signing request is the entity which has been extended equipment authorization by the FCC for the device on which behalf the

certificate signing is requested, according to the criteria established by the WinnForum CBRS PKI Certificate Policy guidelines, and that the certificate attributes reflect this identity.

It enters into a contractual agreement with the entity requesting the CBSD End Entity certificate to be signed according to the requirements in the WinnForum CBRS PKI Certificate Policy guidelines.

1.6 Definitions and Acronyms

See CP §§ 11 and 12.

2 Introduction

2.1 Repositories

In the CBRS PKI, there is no separate entity providing repository services. Rather, each CA is responsible for their repository functions. All CAs that issue certificates under this policy SHALL post all CA certificates and CRLs issued by the CA in a repository that is publicly accessible on the Internet.

2.2 Publication of Certification Information

The CP, CA certificates, and CRLs shall be made publicly available, for example, on the WinnForum website. The CPS for the Root CA will not be published; a redacted version of the CPS will be made publicly available upon request. There is no requirement for the publication of CPSs of sub-CAs that issue certificates under this policy. The CA SHALL protect information not intended for public dissemination.

2.3 Time or Frequency of Publication

Changes to this CP shall be made publicly available within thirty (30) business days of approval by the WinnForum. CA information shall be published promptly after it is made available to the CA.

CA certificates shall be made publicly available within three (3) business days after issuance. Publication requirements for CRLs are provided in CP § 4.9.7.

2.4 Access Controls on Repositories

The CAs SHALL implement controls to prevent unauthorized addition, deletion, or modification of repository entries.

The CPS shall detail what information in the repository shall be exempt from automatic availability and to whom, and under which conditions the restricted information MAY be made available.

3 Identification and Authentication

3.1 Naming

3.1.1 *Types of Names*

For certificates issued under this policy the CA SHALL assign X.501 distinguished names. The subject field in certificates SHALL be populated with a non-empty X.500 distinguished name as specified in CP § 7.1.4. The issuer field of certificates SHALL be populated with a non-empty X.500 Distinguished Name as specified in CP § 7.1.4.

3.1.2 *Need for Names to be Meaningful*

Subscriber Certificates SHALL contain meaningful names with commonly understood semantics permitting the determination of the identity of the organization that is the Subject of the Certificate.

The subject name in CA certificates SHALL match the issuer name in certificates issued by the CA, as required by [RFC 5280].

3.1.3 *Anonymity or Pseudonymity of Subscribers*

CAs SHALL not issue anonymous or pseudonymous certificates.

3.1.4 *Rules for Interpreting Various Name Forms*

Rules for interpreting Distinguished Name forms are specified in X.501.

3.1.5 *Uniqueness of Names*

Name uniqueness for certificates issued by CAs SHALL be enforced. Each CA SHALL enforce name uniqueness within the X.500 name space within its domain. Name uniqueness is not violated when multiple certificates are issued to the same Subscriber. Name uniqueness is enforced for the entire Subject Distinguished Name of the certificate rather than a particular attribute (e.g., the common name). The CA SHALL identify the method for checking uniqueness of Subject Distinguished Names within its domain. In the case of automated issuance of end-entity certificates this requirement MAY be fulfilled by the RA.

3.1.6 *Recognition, Authentication, and Role of Trademarks*

CAs operating under this policy SHALL not issue a certificate knowing that it infringes the trademark of another. Certificate Applicants SHALL not use names in their Certificate Applications that infringe upon the Intellectual Property Rights of others. Neither the WInnForum, nor any CA SHALL be required to determine whether a Certificate Applicant has Intellectual Property Rights in the name appearing in a Certificate Application or to arbitrate, mediate, or otherwise resolve any dispute concerning the ownership of any intellectual property rights, including, without limitation, rights in a domain name, trade name, trademark, or service mark, and WInnForum, and any CBSD CA SHALL be entitled, without liability to any Certificate

Applicant, to reject or suspend any Certificate Application because of such dispute. The WinnForum SHALL resolve disputes involving names and trademarks.

3.2 Initial Identity Validation

3.2.1 *Method to Prove Possession of Private Key*

If the Subscriber generates the certificate key pair, then the CA SHALL prove that the Subscriber possesses the private key by verifying the Subscriber's digital signature on the PKCS #10 Certificate Signing Request (CSR) with the public key in the CSR.

If the key pair is generated by the CA on behalf of a Subscriber; then in this case, proof of possession of the private key by the Subscriber is not required.

The WinnForum MAY approve other methods to prove possession of a private key by a Subscriber.

3.2.2 *Authentication of Organization Identity*

The CA's certificate issuance process SHALL authenticate the identity of the organization named in the Digital Certificate Subscriber Agreement by confirming that the organization:

- Exists in a business database (e.g., Dun and Bradstreet), or alternatively, has organizational documentation issued by or filed with the applicable government (e.g., government issued business credentials) that confirms the existence of the organization, such as articles of incorporation, Certificate of Formation, Charter Documents, or a business license that allow it to conduct business
- Conducts business at the address listed in the agreement
- Is not listed on any of the following U.S. Government denied lists: US Department of Commerce' Bureau of Industry and Security Embargoed Countries List, and the US Department of Commerce' Bureau of Industry and Security Denied Entities List

3.2.3 *Authentication of Individual Identity*

The CA's certificate issuance process SHALL authenticate the individual identity of the:

- Representative submitting the Digital Certificate Subscriber Agreement and Certificate Application, is a duly authorized representative of the organization as an employee, partner, member, agent, etc. and is authorized to act on behalf of the organization
- Corporate Contact listed in the Digital Certificate Subscriber Agreement is an officer in the organization and can act on behalf of the organization
- Administrator listed in the Digital Certificate Subscriber Agreement and Certificate Application, is a duly authorized representative of the organization as an employee, partner, member, agent, etc. and is authorized to act on behalf of the organization.

3.2.4 *Non-verified Subscriber Information*

Non-verifiable information MAY be included in CBRS PKI certificates, such as:

- Organization Unit (OU)

- Any other information designated as non-verified in the certificate

3.2.5 *Validation of Authority*

The CA's certificate issuance process SHALL confirm that the:

- Corporate Contact listed in the Digital Certificate Subscriber Agreement is an officer in the organization who can sign on behalf of the organization and bind the organization to the terms and conditions of the agreement
- Representative submitting the Digital Certificate Subscriber Agreement and certificate application is authorized to act on behalf of the organization
- Administrators listed on the Digital Certificate Subscriber Agreement and certificate application are authorized to act on behalf of the organization
- Contacts listed on the Digital Certificate Subscriber Agreement are authorized to act on behalf of the organization

3.3 **Identification and Authentication for Re-key Requests**

3.3.1 *Identification and Authentication for Routine re-key*

CA and Subscriber certificate re-key shall follow the same procedures as initial certificate issuance. Identity MAY be established through the use of the device's current valid signature key.

3.3.2 *Identification and Authentication for Re-key After Revocation*

Once a certificate has been revoked issuance of a new certificate is required, and the Subscriber SHALL go through the initial identity validation process per CP § 3.2.

3.4 **Identification and Authentication for Revocation Request**

After a certificate has been revoked other than during a renewal or update action, the Subscriber is required to go through the initial registration process described per CP § 3.2 to obtain a new certificate.

Revocation requests SHALL be authenticated and MAY be authenticated using that certificate's public key, regardless of whether or not the associated private key has been compromised.

4 **Certificate Life-Cycle operational requirements**

4.1 **Certificate Application**

The Certificate Application is a package consisting of the following:

- The Digital Certificate Subscriber Agreement
- The Subscriber profile containing contact information
- The Naming Document, which specifies the content to be bound in the certificate
- Any associated fees

A CA and RA SHALL include the processes, procedures, and requirements of their certificate application process in their CPS.

4.1.1 Who Can Submit a Certificate Application

An application for a CA certificate SHALL be submitted by an authorized representative of the applicant CA.

An application for a Subscriber certificates SHALL be submitted by the Subscriber or an authorized representative of the Subscriber.

4.1.2 Enrollment Process and Responsibilities

The enrollment process, for a Certificate Applicant, SHALL include the following:

- Completing the Certificate Application package
- Providing the requested information
- Responding to authentication requests in a timely manner
- Submitting required payment

Communication of information MAY be electronic or out-of-band.

4.2 Certificate Application Processing

4.2.1 Performing Identification and Authentication Functions

The identification and authentication functions SHALL meet the requirements described in CP §§ 3.2 and 3.3.

4.2.2 Approval or Rejection of Certificate Applications

A RA will approve a certificate application if all of the following criteria are met:

- A fully executed Digital Certificate Subscriber Agreement
- A completed and signed Naming Document
- Successful identification and authentication of all required contact information in the Subscriber profile
- Receipt of all requested supporting documentation
- Payment (if applicable) has been received

A RA will reject a certificate application for any of the following:

- The Subscriber fails to execute the required agreement
- An authorized representative fails to sign the certificate application
- Identification and authentication of all required information cannot be completed
- The Subscriber fails to furnish requested supporting documentation
- The Subscriber fails to respond to notices within a specified time
- Payment (if applicable) has not been received

4.2.3 Time to Process Certificate Applications

CAs SHALL begin processing certificate applications within a reasonable time of receipt. There is no time stipulation to complete the processing of an application unless otherwise indicated in the relevant Digital Certificate Subscriber Agreement or CPS.

4.3 Certificate Issuance

4.3.1 CA Actions During Certificate Issuance

To issue a certificate the CA SHALL receive the necessary information from an authorized RA which may include the Naming Document containing certificate profile details and a PKCS #10 certificate signing request (CSR). In the case where the Subscriber has implemented an automated manufacturing process for requesting and issuing end-entity certificates for installation into devices (e.g. CBSD) these actions between the CA and RA may also be automated.

4.3.2 Notification to Subscriber by the CA of Issuance of Certificate

CAs SHALL notify Subscribers that they have created the requested Certificate(s), and provide Subscribers with access to the Certificates by notifying them that their Certificates are available and the means for obtaining them. Certificates SHALL be made available to Subscribers, via download from the CA web site or via a Subscriber's CRA.

In the case where Subscribers have arranged to have a sub-CA operated onsite at their manufacturing facility, the CA is not required to notify the Subscriber of end-entity device certificate issuance and the certificate download requirement does not apply.

4.4 Certificate Acceptance

Before a Subscriber can make effective use of its private key, the CA SHALL explain to the Subscriber its responsibilities as defined in CP § 9.6.3.

In the case of the automated issuance of end entity certificates the Subscriber is the end entity. The manufacturer in this case SHALL ensure that these responsibilities are followed.

4.4.1 Conduct Constituting Certificate Acceptance

The following conduct constitutes certificate acceptance by the Subscriber:

- Downloading a Certificate
- Failure to object timely to the certificate or its content

4.4.2 Publication of the Certificate by the CA

CA certificates SHALL be published in a publicly available repository as specified in CP § 2.1.

This policy makes no stipulation regarding publication of Subscriber certificates.

4.4.3 *Notification of Certificate Issuance by the CA to Other Entities*

The WinnForum SHALL be notified whenever a CA operating under this policy issues a CA certificate.

RAs MAY receive notification of the issuance of certificates they approve.

4.5 **Key Pair and Certificate Usage**

4.5.1 *Subscriber Private Key and Certificate Usage*

Subscriber private key usage SHALL be specified through certificate extensions, including the key usage and extended key usage extensions, in the associated certificate. Per the Digital Certificate Subscriber Agreement, Subscribers SHALL protect their private keys from unauthorized use and SHALL discontinue use of the private key following expiration or revocation of the certificate.

Certificate use SHALL be consistent with the KeyUsage field extensions included in the certificate.

4.5.2 *Relying Party Public Key and Certificate Usage*

Relying Parties SHOULD assess:

- The restrictions on key and certificate usage specified in this CP and which are specified in critical certificate extensions, including the basic constraints and key usage extensions.
- The status of the certificate and all the CA certificates in the certificate chain. If any of the Certificates in the Certificate Chain have been revoked, the Relying Party is solely responsible to determine whether reliance on a Certificate prior to revocation of a Certificate in the Certificate chain is reasonable. Any such reliance is made solely at the risk of the Relying party.

4.6 **Certificate Renewal**

Certificate renewal is the issuance of a new certificate for an existing key pair without changing any information in the certificate except the validity period and serial number.

Using a key pair beyond its intended lifetime can increase its vulnerability to attack. CA certificates SHALL NOT be renewed in this manner. End entity device certificates may be renewed as long as the Subject is notified of the security risks.

4.6.1 *Circumstance for Certificate Renewal*

Device certificate renewal MAY be supported for certificates where the private key associated with the certificate has not been compromised. Device certificates MAY be renewed to maintain continuity of certificate usage

A device certificate MAY be renewed after expiration. The original certificate MAY or MAY NOT be revoked, but SHALL NOT be further re-keyed, renewed, or modified.

4.6.2 Who may Request Renewal

The Subscriber of the certificate or an authorized representative of the Subscriber MAY request a certificate renewal.

4.6.3 Processing Certificate Renewal Requests

For a certificate renewal request, the CA SHALL confirm the identity of the Subscriber in accordance with the requirements specified in CP § 3.2.

4.6.4 Notification of New Certificate Issuance to Subscriber

Notification of issuance of certificate renewal to the Subscriber SHALL be in accordance with CP § 4.3.2.

4.6.5 Conduct Constituting Acceptance of a Renewal Certificate

Conduct constituting Acceptance of a renewed certificate SHALL be in accordance with CP § 4.4.1.

4.6.6 Publication of the Renewal Certificate by the CA

Publication of a renewed certificate SHALL be in accordance with CP § 4.4.2.

4.6.7 Notification of Certificate Issuance by the CA to Other Entities

Notification of the issuance of certificates SHALL be in accordance with CP § 4.4.3.

4.7 Certificate Re-key

Certificate re-key consists of creating a new certificate for a different key pair (and serial number) but can retain the contents of the original certificate's subjectName. Certificate re-key does not violate the requirement for name uniqueness. The new certificate MAY be assigned a different validity period, key identifiers, and/or be signed with a different key.

4.7.1 Circumstance for Certificate Re-key

Certificates MAY be re-keyed:

- To maintain continuity of Certificate usage
- For loss or compromise of original certificate's private key
- By a CA during recovery from key compromise

A certificate MAY be re-keyed after expiration. The original certificate MAY or MAY NOT be revoked, but SHALL NOT be further re-keyed, renewed, or modified.

4.7.2 Who May Request Certification of a New Public Key

The following may request a certificate re-key:

- The Subscriber of the certificate or an authorized representative of the Subscriber
- The CA MAY request a re-key of its own certificate
- The CA MAY re-key its issued certificates during recovery from a CA key compromise
- The WInnForum MAY request re-key of CA certificates

4.7.3 Processing Certificate Re-keying Requests

For certificate re-key, the CA SHALL confirm the identity of the Subscriber in accordance with the requirements specified in this CP § 3.2 for the authentication of an original Certificate Application.

CA certificate re-key SHALL be approved by the WInnForum.

4.7.4 Notification of New Certificate Issuance to Subscriber

Notification of issuance of a re-keyed certificate to the Subscriber SHALL be in accordance with CP § 4.3.2.

4.7.5 Conduct Constituting Acceptance of a Re-keyed Certificate

Conduct constituting Acceptance of a re-keyed certificate SHALL be in accordance with CP § 4.4.1.

4.7.6 Publication of the Re-keyed Certificate by the CA

Publication of a re-keyed certificate SHALL be in accordance with CP § 4.4.2.

4.7.7 Notification of Certificate Issuance by the CA to Other Entities

Notification of the issuance of certificates SHALL be in accordance with CP § 4.4.3.

4.8 Certificate Modification

Modifying a certificate means creating a new certificate that contains a different serial number and that differs in one or more other fields from the original certificate except for the public key and validity period fields.

4.8.1 Circumstance for Certificate Modification

Certificates MAY be modified:

- For a Subscriber organization name change or other Subscriber characteristic change
- To correct subject name attributes or extension settings.

The original certificate MAY or MAY NOT be revoked, but SHALL NOT be further re-keyed, renewed, or modified. If not revoked, the CA will flag the certificate as inactive in its database but will not publish the certificate on a CRL.

4.8.2 *Who May Request Certificate Modification*

The following may request a certificate modification:

- The Subscriber of the certificate or an authorized representative of the Subscriber
- The CA MAY request a certificate modification of its own certificate
- The WinnForum MAY request modification of CA certificates

4.8.3 *Processing Certificate Modification Requests*

For certificate modification requests, the CA SHALL confirm the identity of the Subscriber in accordance with the requirements specified in this CP § 3.2 for the authentication of an initial Certificate Application.

CA certificate modification SHALL be approved by the WinnForum.

4.8.4 *Notification of New Certificate Issuance to Subscriber*

Notification of issuance of a new certificate to the Subscriber SHALL be in accordance with CP § 4.3.2.

4.8.5 *Conduct Constituting Acceptance of Modified Certificate*

Conduct constituting Acceptance of a modified certificate SHALL be in accordance with CP § 4.4.1.

4.8.6 *Publication of the Modified Certificate by the CA*

Publication of a modified certificate SHALL be in accordance with CP § 4.4.2.

4.8.7 *Notification of Certificate Issuance by the CA to Other Entities*

Notification of the issuance of certificates SHALL be in accordance with CP § 4.4.3.

4.9 Subscriber Certificate Revocation and Suspension

4.9.1 *Circumstances for Revocation*

CAs MAY revoke Subscriber certificates under the following circumstances:

The Subscriber or an authorized representative of the Subscriber asks for the certificate to be revoked for any reason whatsoever

- The Subscriber's private key corresponding to the public key in the certificate has been lost or compromised:
 - Disclosed without authorization
 - Stolen
- The Subscriber can be shown to have violated the stipulations of its subscriber agreement
- The Digital Certificate Subscriber Agreement with the Subscriber has been terminated
- There is an improper or faulty issuance of a certificate

- A prerequisite to the issuance of the certificate can be shown to be incorrect;
 - Information in the certificate is known, or reasonably believed, to be false.
 - Any other circumstance that may reasonably be expected to affect the reliability, security, integrity or trustworthiness of the certificate or the cryptographic key pair associated with the certificate.
 - The Subscriber has not submitted payment when due
- Identifying information of the Subscriber in the certificate becomes invalid
- Attributes asserted in the Subscriber's certificate are incorrect
- The Certificate was issued:
 - In a manner not in accordance with the procedures required by the applicable CPS
 - To a person other than the one named as the Subject of the Certificate
 - Without the authorization of the person named as the Subject of such Certificate
- The Subscriber's organization name changes
- The CA suspects or determines that any of the information appearing in the Certificate is inaccurate or misleading
- The continued use of that certificate is harmful to WinnForum or the CA
- The CA finds that in the ordinary course of business that the certificate SHOULD be revoked
- In exigent and/or emergency situations

Whenever any of the above circumstances occur, the associated certificate SHALL be revoked and placed on the CRL. Revoked certificates SHALL be included on all new publications of the certificate status information until the certificates expire.

4.9.2 *Who can Request Revocation*

Within the CBRS PKI, revocation requests MAY be made by:

- The Subscriber of the certificate or any authorized representative of the Subscriber
- The CA, or affiliated RA, for certificates within its domain
- The WinnForum

4.9.3 *Procedure for Revocation Request*

A request to revoke a certificate SHALL identify the date of the request, the certificate to be revoked, the reason for revocation, and allow the requestor to be authenticated. The CA SHALL specify the steps involved in the process of requesting a certificate revocation in their CPS.

Prior to the revocation of a Subscriber Certificate, the CA SHALL authenticate the request. Acceptable procedures for authenticating revocation requests include:

- Having the Subscriber log in to their Certificate Requesting Account and revoking their Certificates via their account portal. The Subscriber will submit their request via their online Certificate Requesting Account, which will employ two-factor authentication, e.g., a USB token with the account administrator's certificate and a PIN.
- Communication with the Subscriber providing reasonable assurances that the person or organization requesting revocation is, in fact the Subscriber. Such communication SHALL

include two or more of the following: telephone confirmation, signed facsimile, signed e-mail, postal mail, or courier service.

- The representative is the Corporate Contact, Administrator, Legal, or Technical contact authenticated in CP § 3.2.5.
- If requested by the automated RA in the case of the automated issuance of end-entity certificates.

CAs are entitled to request the revocation of Subscriber Certificates within the CA's Subdomain. CAs SHALL obtain approval from the WinnForum prior to performing the revocation functions except for revocations pursuant to CP § 4.9.1. The CA SHALL send a written notice and brief explanation for the revocation to the Subscriber. Notwithstanding anything to the contrary in this CP, CAs are authorized to take any action they deem necessary, under the circumstances and without liability to any party, to protect the security and integrity of the CA and/or the CBRS PKI.

The requests from CAs to revoke a CA Certificate SHALL be authenticated by the WinnForum.

Upon revocation of a certificate, the CA that issued the Certificate SHALL publish notice of such revocation in the CA's repository or issue it upon request from the WinnForum.

4.9.4 Revocation Request Grace Period

Revocation requests SHOULD be submitted as promptly as possible within a reasonable time of becoming aware of a revocation circumstance listed in CP § 4.9.1.

4.9.5 Time Within Which CA Shall Process the Revocation Request

CAs SHALL begin investigation of a Certificate revocation request within five (5) business days of receipt to decide whether revocation or other appropriate action is warranted based upon the circumstances of the request in CP § 4.9.1.

4.9.6 Revocation Checking Requirement for Relying Parties

Relying Parties SHOULD check the status of Certificates on which they wish to rely on by checking the certificate status:

- On the most recent CRL from the CA that issued the Certificate
- On the applicable web-based repository
- By using an OCSP responder (if available).

CAs SHALL provide Relying Parties with information within the certificate CRL Distribution Point extension on how to find the appropriate CRL, web-based repository, or OCSP responder (if available) to check the revocation status of certificates issued by the CA.

4.9.7 CRL Issuance Frequency

CRLs SHALL be issued periodically, even if there are no changes to be made, to ensure timeliness of information. Certificate status information MAY be issued more frequently than the issuance frequency described below.

CBRS CAs SHALL update and reissue CRLs at least (i) once every twelve (12) months and (ii) within 24 hours after revoking a Certificate, with the value of the *nextUpdate* field not more than twelve (12) months beyond the value of the *thisUpdate* field.

4.9.8 Maximum Latency for CRLs

CRLs SHOULD be published immediately and SHALL be published within 24 hours of generation.

4.9.9 On-line Revocation/Status Checking Availability

CAs SHALL have a web-based repository that permits Relying Parties to make online inquiries regarding revocation and other Certificate status information. CAs SHALL provide Relying Parties with information on how to find the appropriate repository to check Certificate status and how to find the correct OCSP responder (if available).

4.9.10 On-line Revocation Checking Requirements

A Relying Party SHOULD check the status of a certificate on which they wish to rely on. If a Relying Party does not check the status of a Certificate by consulting the most recent CRL, the Relying Party SHOULD check the Certificate status by consulting the applicable on-line repository or by requesting Certificate status using the applicable OCSP responder (where available). If the Relying Party does not check the status of the certificates as described in this paragraph or the CPS, the Relying Party is estopped from asserting any claim against the CA related to or arising out of the Relying Party's reliance on the certificate.

4.9.11 Other Forms of Revocation Advertisements Available

A CA may also use other methods to publicize the certificates it has revoked. Any alternative method SHALL meet the following requirements:

- The alternative method SHALL be described in the CA's CPS
- The alternative method SHALL meet the issuance and latency requirements for CRLs stated in CP §§ 4.9.7 and 4.9.8

4.9.12 Special Requirements Regarding Key Compromise

When a CA certificate is revoked a CRL SHALL be issued within 24 hours of notification.

4.9.13 Circumstances for Suspension

The CBRS PKI does not offer suspension services for its Certificates.

4.9.14 Who can Request Suspension

No stipulation.

4.9.15 Procedure for Suspension Request

No stipulation.

4.9.16 Limits on Suspension Period

No stipulation.

4.10 Certificate Status Services

4.10.1 Operational Characteristics

Certificate status SHALL be available via CRL through a URL specified in a CA's CPS, and MAY be available via LDAP directory or OCSP responder.

4.10.2 Service Availability

Certificate Status Services SHALL be available 24 x 7. CRL and OCSP capability SHOULD provide a response time of ten (10) seconds or less under normal operating conditions.

4.10.3 Optional Features

OCSP is an optional certificate status feature that is not available for all products and SHALL be specifically enabled for other products.

4.11 End of Subscription

End of subscription SHALL be stipulated in the Digital Certificate Subscriber Agreement.

4.12 Key Escrow and Recovery

4.12.1 Key Escrow and Recovery Policy and Practices

No stipulation.

4.12.2 Session Key Encapsulation and Recovery Policy and Practices

No stipulation.

5 Facility, Management, and Operational Controls

All entities performing CA functions SHALL implement and enforce the following physical, procedural, logical, and personnel security controls for a CA.

5.1 Physical Controls

CA equipment SHALL be protected from unauthorized access while the cryptographic module is installed and activated. The CA SHALL implement physical access controls to reduce the risk of

equipment tampering even when the cryptographic module is not installed and activated. CA cryptographic tokens SHALL be protected against theft, loss, and unauthorized use.

All the physical control requirements specified below apply equally to the Common Policy Root CA and subordinate CAs, and any remote workstations used to administer the CAs except where specifically noted.

5.1.1 Site Location and Construction

All CA operations SHALL be conducted within a physically protected environment that deters, prevents, and detects unauthorized use of, access to, or disclosure of sensitive information and systems. The location and construction of the facility housing the CA equipment, as well as sites housing remote workstations used to administer the CAs, SHALL be consistent with facilities used to house high-value, sensitive information. The site location and construction, when combined with other physical security protection mechanisms such as guards, high security locks, and intrusion sensors, SHALL provide robust protection against unauthorized access to the CA equipment and records.

Such requirements are based in part on the establishment of physical security tiers. A tier is a barrier such as a locked door or closed gate that provides mandatory access control for individuals and requires a positive response (e.g., door unlocks or gate opens) for each individual to proceed to the next area. Each successive tier provides more restricted access and greater physical security against intrusion or unauthorized access. Moreover, each physical security tier encapsulates the next inner tier, such that an inner tier SHALL be fully contained in an outside tier and cannot have a common outside wall with the outside tier, the outermost tier being the outside barrier of the building (e.g., a perimeter fence or outside wall).

CAs SHALL construct the facilities housing their CA functions with at least five physical security tiers, Tiers 1 through 5. CAs SHALL perform all validation operations within Tier 3 or higher. CAs SHALL place Information Services systems necessary to support CA functions in Tier 4 or higher. Online and offline cryptographic modules SHALL be placed in Tier 5 or higher. CAs SHALL further protect offline cryptographic modules by placing them within Tier 5 or higher. CAs using Automated Administration SHALL place the Automated Administration server in Tier 4 or higher.

CAs SHALL describe their Site Location and Construction in more detail in their CPS.

5.1.2 Physical Access

Access to each tier of physical security, constructed in accordance with CP § 5.1.1, SHALL be auditable and controlled so that only authorized personnel can access each tier.

CAs SHALL control access to their CA facilities including:

- Minimizing exposure of privileged functions through definition of function-specific roles or authorization groups
- Access control enforcement of these roles or groups
- Use of proximity card identification badges

- Automated logging of access into and out of the facility
- The use of tamper resistant physical intrusion alarm systems to detect break-ins or unauthorized access to physical security tiers within the facility
- Automated notification to outside alarm monitoring agency of a potential security breach when facility-based guards are not present.
- Video surveillance [optional]

Although not required, the use of biometric readers (e.g., hand geometry or iris scan) that provide two-factor authentication is recommended.

At a minimum, the physical access controls for CA equipment, as well as remote workstations used to administer the CAs, SHALL:

- Ensure that no unauthorized access to the hardware is permitted.
- Ensure that all removable media and paper containing sensitive plain-text information is stored in secure containers.
- Be manually or electronically monitored for unauthorized intrusion at all times.
- Ensure an access log is maintained and inspected periodically.
- Require two-person physical access control to both the cryptographic module and computer systems.

When not in use, removable cryptographic modules, activation information used to access or enable cryptographic modules, and CA equipment SHALL be placed in secure containers. Activation data SHALL be either memorized or recorded and stored in a manner commensurate with the security afforded the cryptographic module, and SHALL NOT be stored with the cryptographic module or removable hardware associated with remote workstations used to administer the CA.

A security check of the facility housing the CA equipment or remote workstations used to administer the CAs SHALL occur if the facility is to be left unattended. At a minimum, the check SHALL verify the following:

- The equipment is in a state appropriate to the current mode of operation (e.g., that cryptographic modules are in place when —open, and secured when —closed, and for the CA, that all equipment other than the repository is shut down)
- Any security containers are properly secured
- Physical security systems (e.g., door locks, vent covers) are functioning properly
- The area is secured against unauthorized access

A person or group of persons SHALL be made explicitly responsible for making such checks. When a group of persons is responsible, a log identifying the person performing a check at each instance SHALL be maintained. If the facility is not continuously attended, the last person to depart SHALL initial a sign-out sheet that indicates the date and time and asserts that all necessary physical protection mechanisms are in place and activated.

5.1.3 *Power and Air Conditioning*

CA facilities SHALL be equipped with primary and backup power systems to ensure continuous, uninterrupted access to electric power. Also, these facilities SHALL be equipped with primary and backup heating/ventilation/air conditioning systems to control temperature and relative humidity.

The CA SHALL have backup capability sufficient to lock out input, finish any pending actions, and record the state of the equipment automatically before lack of power or air conditioning causes a shutdown. The repositories (containing CA certificates and CRLs) SHALL be provided with uninterrupted power sufficient for a minimum of 6 hours operation in the absence of commercial power, to maintain availability and avoid denial of service.

5.1.4 *Water Exposures*

CA facilities SHALL be constructed, equipped and installed, and procedures SHALL be implemented, to prevent floods or other damaging exposure to water. Potential water damage from fire prevention and protection measures (e.g., sprinkler systems) are excluded from this requirement.

5.1.5 *Fire Prevention and Protection*

CA facilities SHALL be constructed and equipped, and procedures SHALL be implemented, to prevent and extinguish fires or other damaging exposure to flame or smoke. These measures SHALL meet all local applicable safety regulations.

5.1.6 *Media Storage*

CAs SHALL protect the media holding back ups of critical system data or any other sensitive information from water, fire, or other environmental hazards, and SHALL use protective measures to deter, detect, and prevent the unauthorized use of, access to, or disclosure of such media.

5.1.7 *Waste Disposal*

CAs SHALL implement procedures for the disposal of waste (paper, media, or any other waste) to prevent the unauthorized use of, access to, or disclosure of waste containing Confidential/Private Information.

CA media and documentation that are no longer needed for operations SHALL be destroyed in a secure manner. For example, paper documentation SHALL be shredded, burned, or otherwise rendered unrecoverable.

5.1.8 *Off-site Backup*

CAs SHALL maintain backups of critical system data or any other sensitive information, including audit data, in a secure off-site facility. Full system backups sufficient to recover from system failure SHALL be made on a periodic schedule, and described in a CA's CPS. Backups are to be performed and stored off-site not less than once per week. At least one full backup copy SHALL be stored at an off-site location (separate from CA equipment). Only the latest full backup need be

retained. The backup SHALL be stored at a site with physical and procedural controls commensurate to that of the operational CA. An active/active infrastructure, whereby data are synchronized between two sites and one site alone is capable of hosting the CBRS PKI in the event of a disaster at the other site, will meet the requirements of off-site backup.

Requirements for CA private key backup are specified in CP § 6.2.4.

5.2 Procedural Controls

Procedural controls are requirements on roles that perform functions that can introduce security problems if not carried out properly, whether accidentally or maliciously. The people selected to fill these roles SHALL be extraordinarily responsible, or the integrity of the CA will be weakened. The functions performed in these roles form the basis of trust for the entire PKI. Two approaches are taken to increase the likelihood that these roles can be successfully carried out. The first ensures that the person filling the role is trustworthy and properly trained. The second distributes the functions among more than one person, so that any malicious activity would require collusion.

5.2.1 *Trusted Roles*

Employees, contractors, and consultants that are designated to manage the CA's trustworthiness SHALL be considered to be "Trusted Persons" serving in "Trusted Positions." Persons seeking to become Trusted Persons-SHALL meet the screening requirements of CP § 5.3.

CAs SHALL consider the categories of their personnel identified in this section as Trusted Persons having a Trusted Position. Trusted Persons include all employees, contractors, and consultants that have access to or control authentication or cryptographic operations that may materially affect:

- The validation of information in Certificate Applications
- The acceptance, rejection, or other processing of Certificate Applications, revocation requests, or renewal requests, or enrollment information
- The issuance, or revocation of Certificates, including (in the case of Processing Centers) personnel having access to restricted portions of its repository
- The handling of Subscriber information or requests

Trusted Persons include, but are not limited to, customer service personnel, CA system administrators, designated engineering personnel, CA operators, auditor, and executives that are designated to manage infrastructural trustworthiness.

5.2.2 *Number of Persons Required per Task*

Multiparty control procedures are designed to ensure that at a minimum, two trusted personnel are required to have either physical or logical access to the CA. Access to CA cryptographic hardware SHALL be strictly enforced by multiple Trusted Persons throughout its lifecycle, from incoming receipt and inspection to final logical and/or physical destruction. Once a CA device is activated with operational keys, further access controls SHALL be invoked to maintain split control over both physical and logical access to the device. Persons with physical access to CA modules do not hold "Secret Shares" to activate the CA and vice versa.

Two or more persons are required for the following tasks:

- Access to CA hardware
- Management of CA cryptographic hardware
- CA key generation
- CA signing key activation
- CA private key backup

Where multiparty control is required, at least one of the participants SHALL be an Administrator. All participants SHALL serve in a trusted role as defined in CP § 5.2.1. Multiparty control SHALL NOT be achieved using personnel that serve in the Auditor trusted role. CAs SHALL establish, maintain, and enforce rigorous control procedures to ensure the segregation of duties based on job responsibility and to ensure that multiple Trusted Persons are required to perform sensitive tasks.

Other manual operations such as the validation and issuance of Certificates, not issued by an automated validation and issuance system, require the participation of at least 2 Trusted Persons, or a combination of at least one trusted person and an automated validation and issuance process. Manual operations for Key Recovery MAY optionally require the validation of two (2) authorized Administrators.

5.2.3 Identification and Authentication for Each Role

CAs SHALL confirm the identity and authorization of all personnel seeking to become Trusted Persons before such personnel are:

- Issued access devices and granted access to the required facilities;
- Given electronic credentials to access and perform specific functions on CA systems.

Authentication of identity SHALL include the personal (physical) presence of such personnel before Trusted Persons performing HR or security functions within an entity and a check of well-recognized forms of identification, such as passports and driver's licenses. Identity SHALL be further confirmed through background checking procedures in CP § 5.3.

5.2.4 Roles Requiring Separation of Duties

Roles requiring Separation of duties include (but are not limited to) the:

- Validation of information in Certificate Applications;
- Acceptance, rejection, or other processing of Certificate Applications, revocation requests, key recovery requests or renewal requests, or enrollment information;
- Issuance, or revocation of Certificates, including personnel having access to restricted portions of the repository;
- Handling of Subscriber information or requests
- Generation, issuing or destruction of a CA certificate
- Loading of a CA to a Production environment

No individual SHALL have more than one trusted role. CA SHALL have in place procedure to identify and authenticate its users and SHALL ensure that no user identity can assume multiple roles.

5.3 Personnel Controls

5.3.1 *Qualifications, Experience, and Clearance Requirements*

CAs SHALL require that personnel assigned to Trusted roles have the requisite background, qualifications, and experience or be provided the training needed to perform their prospective job responsibilities competently and satisfactorily. The requirements governing the qualifications, selection and oversight of individuals who operate, manage, oversee, and audit the CA SHALL be set forth in the CPS.

5.3.2 *Background Check Procedures*

CAs SHALL conduct background check procedures for personnel tasked become Trusted Persons. These procedures SHALL be subject to any limitations on background checks imposed by local law. To the extent one of the requirements imposed by this section cannot be met due to a prohibition or limitation in local law, the investigating entity SHALL utilize a substitute investigative technique permitted by law that provides substantially similar information, including but not limited to obtaining a background check performed by an applicable agency. Background investigations MAY include a:

- Confirmation of previous employment
- Check of one or more professional references
- Confirmation of the highest or most relevant educational degree obtained
- Search of criminal records (local, state or provincial, and national)
- Check of credit/financial records
- Search of driver's license records

Factors revealed in a background check that MAY be considered grounds for rejecting candidates for Trusted Positions or for taking action against an existing Trusted Person (all subject to and in accordance with applicable law) MAY include but is not limited to the following:

- Misrepresentations made by the candidate or Trusted Person
- Highly unfavorable or unreliable personal references
- Certain criminal convictions
- Indications of a lack of financial responsibility

Background checks SHALL be repeated for personnel holding Trusted Positions at least every five (5) years.

5.3.3 *Training Requirements*

CAs SHALL provide their personnel with the requisite on-the-job training needed for their personnel to perform their job responsibilities relating to CA operations competently and satisfactorily. They SHALL also periodically review their training programs, and their training SHALL address the elements relevant to functions performed by their personnel.

Training programs SHALL address the elements relevant to the particular environment of the person being trained, including, without limitation:

- Security principles and mechanisms of the CA and the its environment

- Hardware and software versions in use
- All duties the person is expected to perform
- Incident and Compromise reporting and handling
- Disaster recovery and business continuity procedures
- The stipulations of this policy

5.3.4 Retraining Frequency and Requirements

CAs SHALL provide refresher training and updates to their personnel to the extent and frequency required to ensure that such personnel maintain the required level of proficiency to perform their job responsibilities competently and satisfactorily.

All individuals responsible for PKI roles SHALL be made aware of changes in the CA operation. Any significant change to the operations SHALL have a training (awareness) plan, and the execution of such plan SHALL be documented. Examples of such changes are CA software or hardware upgrade, changes in automated security systems, and relocation of equipment.

Documentation SHALL be maintained identifying all personnel who received training and the level of training completed.

5.3.5 Job Rotation Frequency and Sequence

No stipulation.

5.3.6 Sanctions for Unauthorized Actions

CAs SHALL establish, maintain, and enforce policies for the discipline of personnel following unauthorized actions. Disciplinary actions MAY include measures up to and including termination and SHALL be commensurate with the frequency and severity of the unauthorized actions.

5.3.7 Independent Contractor Requirements

CAs SHALL permit independent contractors or consultants to become Trusted Persons only to the extent necessary to accommodate clearly defined outsourcing relationships. CAs SHOULD only use contractors or consultants as Trusted Persons if the CA does not have suitable employees available to fill the roles of Trusted Persons. Otherwise, independent contractors and consultants SHALL be escorted and directly supervised by Trusted Persons when they are given access to the CA and its secure facility.

Contractors fulfilling trusted roles are subject to all personnel requirements stipulated in this policy and SHALL establish procedures to ensure that any subcontractors perform in accordance with this policy.

5.3.8 Documentation Supplied to Personnel

CAs SHALL give their personnel the requisite training and documentation needed to perform their job responsibilities competently and satisfactorily.

5.4 Audit Logging Procedures

Audit log files SHALL be generated for all events relating to the security of the CA. Where possible, the audit logs SHALL be automatically collected. Where this is not possible, a logbook, paper form, or other physical mechanism SHALL be used. All CA audit logs, both electronic and non-electronic, SHALL be retained and made available during compliance audits. In the case of the automated issuance of end-entity certificates, the automated RA MAY perform the tasks mentioned in this section if delegated by the CA.

5.4.1 Types of Events Recorded

All auditing capabilities of the CA operating system and applications SHALL be enabled during installation. All audit logs, whether recorded automatically or manually, SHALL contain the date and time, the type of event, and the identity of the entity that caused the event.

CAs SHALL record in audit log files all events relating to the security of the CA system, including, without limitation:

- Physical Access / Site Security:
 - Personnel access to room housing CA
 - Access to the CA server
 - Known or suspected violations of physical security
- CA Configuration:
 - CA hardware configuration
 - Installation of the operating system
 - Installation of the CA software
 - System configuration changes and maintenance
 - Installation of hardware cryptographic modules
 - Cryptographic module lifecycle management-related events (*e.g.*, receipt, use, de-installation, and retirement)
- Account Administration:
 - System Administrator accounts
 - Roles and users added or deleted to the CA system
 - Access control privileges of user accounts
 - Attempts to create, remove, set passwords or change the system privileges of the privileged users (trusted roles)
 - Attempts to delete or modify audit logs
 - Changes to the value of maximum authentication attempts
 - Resetting operating system clock
 - Electrical power outages
- CA Operational events:
 - Key generation
 - Start-up and shutdown of CA systems and applications
 - Changes to CA details or keys
 - Records of the destruction of media containing key material, activation data, or personal Subscriber information)
- Certificate lifecycle events:

- Issuance
- Re-key
- Renew
- Revocation
- Trusted employee events:
 - Logon and logoff
 - attempts to create, remove, set passwords or change the system privileges of the privileged users
 - Unauthorized attempts to the CA system,
 - Unauthorized attempts to access system files,
 - Failed read and write operations on the Certificate,
 - Personnel changes
- Token events:
 - Serial number of tokens shipped to Subscriber
 - Account Administrator Certificates
 - Shipment of tokens
 - Tokens driver versions

5.4.2 *Frequency of Processing Log*

CAs SHALL review their audit logs in response to alerts based on irregularities and incidents within their CA systems. Review of the audit log SHALL be required at least once every three months. CAs SHALL compare their audit logs with supporting manual and electronic logs when any action is deemed suspicious.

Audit log processing SHALL consist of a review of the audit logs and documenting the reason for all significant events in an audit log summary. Audit log reviews SHALL include a verification that the log has not been tampered with, a brief inspection of all log entries, and a more thorough investigation of any alerts or irregularities in the logs. Actions taken based on audit log reviews SHALL be documented.

5.4.3 *Retention Period for Audit Log*

Audit logs SHALL be retained onsite at least two (2) months after processing and thereafter archived in accordance with CP § 5.5. The individual who removes audit logs from the CA system SHALL be different from the individuals who, in combination, command the CA signature key.

5.4.4 *Protection of Audit Log*

Audit logs SHALL be protected from unauthorized viewing, modification, deletion, or other tampering. CA system configuration and procedures SHALL be implemented together to ensure that only authorized people archive or delete security audit data. Procedures SHALL be implemented to protect archived data from deletion or destruction before the end of the security audit data retention period (note that deletion requires modification access).

5.4.5 *Audit Log Backup Procedures*

Incremental backups of audit logs SHALL be created frequently, at least monthly.

5.4.6 *Audit Collection System (Internal vs. External)*

The audit log collection system MAY or MAY NOT be external to the CA system. Automated audit processes SHALL be invoked at system or application startup and cease only at system or application shutdown. Audit collection systems SHALL be configured such that security audit data is protected against loss (e.g., overwriting or overflow of automated log files). Should it become apparent that an automated audit system has failed, and the integrity of the system or confidentiality of the information protected by the system is at risk, operations SHALL be suspended until the problem has been remedied.

5.4.7 *Notification to Event-Causing Subject*

Where an event is logged by the audit collection system, no notice is required to be given to the individual, organization, device, or application that caused the event.

5.4.8 *Vulnerability Assessments*

The CA SHALL perform routine self-assessments of security controls for vulnerabilities. Events in the audit process are logged, in part, to monitor system vulnerabilities. The assessments SHALL be performed following an examination of these monitored events. The assessments SHALL be based on real-time automated logging data and SHALL be performed at least on an annual basis as input into an entity's annual Compliance Audit.

The audit data SHOULD be reviewed by the security auditor for events such as repeated failed actions, requests for privileged information, attempted access of system files, and unauthenticated responses. Security auditors SHOULD check for continuity of the audit data.

5.5 **Records Archival**

CA archive records SHALL be sufficiently detailed to determine the proper operation of the CA and the validity of any certificate (including those revoked or expired) issued by the CA. Records MAY be kept in the form of either computer-based messages or paper-based documents, provided their indexing, storage, preservation, and reproduction are accurate, reliable, and complete.

5.5.1 *Types of Records Archived*

The CA records SHALL include all relevant evidence in the recording entity's possession, including, without limitation:

- Time stamps
- Certificate policy
- Certification practice statement
- Contractual obligations and other agreements concerning operations of the CA System and equipment configuration

- Modifications and updates to system or configuration
- Certificate request documentation
- Records of all actions taken on certificates issued and/or published
- Record of re-key
- Revocation request information
- Records of all CRLs issued and/or published
- Compliance Auditor reports
- Appointment of an individual to a Trusted Role
- Destruction of cryptographic modules
- All certificate compromise notifications

The RA records SHALL include all relevant evidence in the recording entity's possession, including, without limitation:

- Digital Certificate Subscriber Agreements
- Token lifetime (issuance, recovery, destruction, etc.) documentation
- All CRLs issued and/or published
- Compliance Auditor reports
- Destruction of cryptographic modules
- All certificate compromise notifications

The following shall also be included in RA records only in the case of the automated issuance of end-entity certificates:

- Contractual obligations and other agreements concerning operations of the CA System and equipment configuration.
- Records of all actions taken on certificates issued and/or published.
- Revocation request information

5.5.2 *Retention Period for Archive*

Archive records SHALL be kept for a minimum of 10 years without any loss of data.

5.5.3 *Protection of Archive*

An entity maintaining an archive of records SHALL protect the archive so that only the entity's authorized Trusted Persons are able to obtain access to the archive. The archive SHALL be protected against unauthorized viewing, modification, deletion, or other tampering. The archive media and the applications required to process the archive data SHALL be maintained to ensure that the archive data can be accessed for the time period set forth in CP § 5.5.2.

5.5.4 *Archive Backup Procedures*

Entities compiling electronic information SHALL incrementally back up system archives of such information on a daily basis and perform full backups on a weekly basis. Copies of paper-based records SHALL be maintained in an off-site secure facility.

5.5.5 *Requirements for Time-Stamping of Records*

CA archive records SHALL be automatically time-stamped as they are created. System clocks used for time-stamping SHALL be maintained in synchrony with an authoritative time standard.

5.5.6 *Archive Collection System (Internal or External)*

Archive data may be collected in any expedient manner.

5.5.7 *Procedures to Obtain and Verify Archive Information*

Only authorized Trusted Personnel are able to obtain access to the archive. The integrity of the information is verified as usable when it is restored.

5.6 **Key Changeover**

When a CA certificate is rekeyed only the new key is used to sign certificates from that time on. If the old private key is used to sign OCSP responder certificates or CRLs that cover certificates signed with that key, the old key SHALL be retained and protected.

A CA Certificate may be renewed if the CA's Superior Entity reconfirms the identity of the CA. Following such reconfirmation, the Superior Entity SHALL either approve or reject the renewal application.

When a CA updates its private signature key and thus generates a new public key, the CA SHALL notify all CAs, RAs, and Subscribers that rely on the CA's certificate that it has been changed.

5.7 **Compromise and disaster recovery**

5.7.1 *Incident and Compromise Handling Procedures*

The WinnForum SHALL be notified if any CAs operating under this policy experience the following:

- Suspected or detected compromise of the CA systems
- Physical penetration of the site housing the CA systems
- Successful denial of service attacks on CA components

The WinnForum will take appropriate steps to protect the integrity of the CBRS PKI.

The CA's Management Authority SHALL reestablish operational capabilities as quickly as possible in accordance with procedures set forth in the CA's CPS.

5.7.2 *Computing Resources, Software, and/or Data are Corrupted*

When computing resources, software, and/or data are corrupted, CAs operating under this policy SHALL respond as follows:

- Before returning to operation, ensure that the system's integrity has been restored.
- The WinnForum SHALL be notified as soon as possible.

- A report of the incident and a response to the event, SHALL be promptly made by the affected CA or RA in accordance with the documented incident and Compromise reporting and handling procedures in the applicable CPS.

5.7.3 *Entity Private Key Compromise Procedures*

In the event of a CA private key compromise, the following operations SHALL be performed.

- The WinnForum SHALL be immediately informed.
- If the CA signature keys are not destroyed, CA operation SHALL be reestablished, giving priority to the ability to generate certificate status information.
- If the CA signature keys are destroyed, CA operation SHALL be reestablished as quickly as possible, giving priority to the generation of a new CA key pair.
- The CA SHALL generate new keys in accordance with CP § 6.1.1.
- Initiate procedures to notify Subscribers of the compromise.
- Subscriber certificates MAY be renewed automatically by the CA under the new key pair (see CP §4.6), or the CA MAY require Subscribers to repeat the initial certificate application process.

5.7.4 *Business continuity capabilities after a disaster*

Entities operating CAs SHALL develop, test, and maintain a Disaster Recovery Plan designed to mitigate the effects of any kind of natural or man-made disaster. The Plan SHALL identify conditions for activating the recovery and what constitutes an acceptable system outage and recovery time for the restoration of information systems services and key business functions within a defined recovery time objective (RTO).

Additionally, the Plan SHALL include:

- Frequency for taking backup copies of essential business information and software,
- Requirement to store critical cryptographic materials (i.e., secure cryptographic device and activation materials) at an alternate location,
- Separation distance of the Disaster recovery site to the CA’s main site,
- Procedures for securing the Disaster facility during the period of time following a disaster and prior to restoring a secure environment either at the original or a remote site.

The DRP SHALL include administrative requirements including:

- Maintenance schedule for the plan
- Awareness and education requirements
- Responsibilities of the individuals
- Regular testing of contingency plans

CAs SHALL have the capability of restoring or recovering essential operations within twenty-four (24) hours following a disaster with, at a minimum, support for the following functions: Certificate issuance, Certificate revocation, and publication of revocation information. The disaster recovery equipment SHALL have physical security protections comparable to the production CA system, which includes the enforcement of physical security tiers.

A CA's disaster recovery plan SHALL make provisions for full recovery within one week following a disaster at the primary site.

5.8 CA or RA Termination

When a CA operating under this policy terminates operations before all certificates have expired, the CA signing keys SHALL be surrendered to the WinnForum. Prior to CA termination, the CA SHALL provide archived data to an archive facility as specified in the CPS. As soon as possible, the CA will advise all other organizations to which it has issued certificates of its termination, using an agreed-upon method of communication specified in the CPS.

CAs that have ceased issuing new certificates but are continuing to issue CRLs until all certificates have expired are required to continue to conform with all relevant aspects of this policy (e.g., audit logging and archives).

The termination of a CBRS CA SHALL be subject to the contract between the terminating CA and its Superior Entity. A terminating CA and its Superior Entity SHALL, in good faith, use commercially reasonable effort to agree on a termination plan that minimizes disruption to Subscribers and Relying Parties. The termination plan MAY cover issues such as:

- Providing notice to parties affected by the termination, such as Subscribers and Relying Parties,
- Who bears the cost of such notice, the terminating CA or the Superior Entity,
- The revocation of the Certificate issued to the CA by the Superior Entity,
- The preservation of the CA's archives and records for the time periods required in CP § 5.4.6,
- The continuation of Subscriber and customer support services,
- The continuation of revocation services, such as the issuance of CRLs or the maintenance of online status checking services,
- The revocation of unexpired unrevoked Certificates of Subscribers and subordinate CAs, if necessary,
- The payment of compensation (if necessary) to Subscribers whose unexpired unrevoked Certificates are revoked under the termination plan or provision, for the issuance of substitute Certificates by a successor CA,
- Disposition of the CA's private key and the hardware token containing such private key, and
- Provisions needed for the transition of the CA's services to a successor CA.

6 Technical Security Controls

6.1 Key Pair Generation and Installation

6.1.1 Key Pair Generation

Key pair generation SHALL be performed using FIPS 140 validated cryptographic modules and processes that provide the required cryptographic strength of the generated keys and prevent the

loss, disclosure, modification, or unauthorized use of private keys. Any pseudo-random numbers use and parameters for key generation material SHALL be generated by a FIPS-approved method.

CA keys SHALL be generated in a Key Generation Ceremony using multi-person control for CA key pair generation, as specified in CP § 6.2.2.

CA key pair generation SHALL create a verifiable audit trail that the security requirements for procedures were followed. The documentation of the procedure SHALL be detailed enough to show that appropriate role separation was used. An independent third party SHALL validate the execution of the key generation procedures either by witnessing the key generation or by examining the signed and documented record of the key generation.

6.1.2 Private Key Delivery to Subscriber

Subscriber key pair generation SHALL be performed by the Subscriber or CA. If the Subscribers themselves generate private keys, then private key delivery to a Subscriber is unnecessary.

When CAs generate key pairs on behalf of the Subscriber, the private key SHALL be delivered securely to the Subscriber. Private keys SHALL be delivered electronically or on a hardware cryptographic module. In all cases, the following requirements SHALL be met:

- The CA SHALL not retain any copy of the key for more than two week after delivery of the private key to the Subscriber.
- CAs SHALL use FIPS 140-2 Level 3 systems and deliver private keys to Subscribers via SSL/TLS and SHALL secure such delivery through the use of a PKCS#8 package or, at the CAs sole discretion, any other comparably equivalent means (e.g., PKCS#12 package) in order to prevent the loss, disclosure, modification, or unauthorized use of such private keys.
- Where key pairs are pre-generated on hardware tokens, the entities distributing such tokens SHALL use best efforts to provide physical security of the tokens to prevent the loss, disclosure, modification, or unauthorized use of the private keys on them. The RA SHALL maintain a record of the Subscriber acknowledgment of receipt of the token.
- The Subscriber SHALL acknowledge receipt of the private key(s).
- Delivery SHALL be accomplished in a way that ensures that the correct tokens and activation data are provided to the correct Subscribers.
 - For hardware modules, accountability for the location and state of the module SHALL be maintained until the Subscriber accepts possession of it.
 - For electronic delivery of private keys, the key material SHALL be encrypted using a cryptographic algorithm and key size at least as strong as the private key. Activation data SHALL be delivered using a separate secure channel.

6.1.3 Public Key Delivery to Certificate Issuer

When a public key is transferred to the issuing CA to be certified, it SHALL be delivered through a mechanism validating the identity of the Subscriber and ensuring that the public key has not been altered during transit and that the Certificate Applicant possesses the private key corresponding to the transferred public key. The Certificate Applicant SHALL deliver the public key in a PKCS#10 CSR or an equivalent method ensuring that the public key has not been altered during transit; and

the Certificate Applicant possesses the private key corresponding to the transferred public key. The Certificate Applicant will submit the CSR via their online Certificate Requesting Account, which employs two-factor authentication, e.g., a USB token with the account administrator’s certificate and a PIN (this procedure is not applicable in the case of the automated issuance of end-entity certificates).

6.1.4 CA Public Key Delivery to Relying Parties

The Root CA public key certificate SHALL be delivered to Relying Parties in a secure fashion to preclude substitution attacks. Acceptable methods for certificate delivery are:

- The Root CA Certificate is delivered as part of a Subscriber’s certificate request.
- Secure distribution of Root CA certificates through secure out-of-band mechanisms.
- Downloading the Root CA certificates from trusted web sites (e.g., WinnForum web site). The Root CA SHALL calculate the hash of the certificate before posting it on a website so that it can be made available via out-of-band to Relying Parties to validate the posted Root CA certificate.

6.1.5 Public Key Parameters Generation and Quality Checking

Elliptic Curve Cryptography (ECC) public key parameters SHALL be selected from the set specified in CP § 7.1.3.

6.1.6 Key Usage Purposes (as per X.509 v3 Key Usage Field)

Table 2 shows the specific keyUsage extension settings for CBRS CA certificates and specifies that all CA certificates (i.e., Root CAs, Sub-CAs):

- SHALL include a keyUsage extension
- SHALL set the criticality of the keyUsage extension to TRUE
- SHALL assert the keyCertSign bit and the cRLSign bit in the key usage extension

Table 2: keyUsage Extension for all CA certificates

Field	Format	Criticality	Value	Comment
keyUsage	BIT STRING	TRUE	{ id-ce 15 }	Included in all CA certificates
digitalSignature	(0)		0	Not Set
nonRepudiation	(1)		0	Not Set
keyEncipherment	(2)		0	Not Set
dataEncipherment	(3)		0	Not Set
keyAgreement	(4)		0	Not Set
keyCertSign	(5)		1	Set
cRLSign	(6)		1	Set

encipherOnly	(7)		0	Not Set
decipherOnly	(8)		0	Not Set

Table 3 shows the specific keyUsage extension settings for CBRS Subscriber end-entitydevice certificates that contain RSA or ECC public keys and specifies that all Subscriber device certificates:

- SHALL include a keyUsage extension
- SHALL set the criticality of the keyUsage extension to TRUE
- SHALL assert the digitalSignature bit
- SHALL assert the keyEncipherment bit for RSA public keys
- SHALL assert the keyAgreement bit for ECC public keys

Table 3: keyUsage Extension for Subscriber Certificates with RSA Public Keys

Field	Format	Criticality	Value	Comment
keyUsage	BIT STRING	TRUE	{ id-ce 15 }	Included in all Subscriber certificates
digitalSignature	(0)		1	Set
nonRepudiation	(1)		0	Not Set
keyEncipherment	(2)		1	Set for RSA
dataEncipherment	(3)		0	Not Set
keyAgreement	(4)		0	Set for ECC
keyCertSign	(5)		0	Not Set
cRLSign	(6)		0	Not Set
encipherOnly	(7)		0	Not Set
decipherOnly	(8)		0	Not Set

6.2 Private Key Protection and Cryptographic Module Engineering Controls

6.2.1 Cryptographic Module Standards and Controls

CA Private keys within the CBRS PKI SHALL be protected using FIPS 140-2 Level 3 systems. Private key holders SHALL take necessary precautions to prevent the loss, disclosure, modification, or unauthorized use of such Private Keys in accordance with this CP and contractual obligations specified in the appropriate WinnForum Agreement.

The relevant standard for cryptographic modules is Security Requirements for Cryptographic Modules [FIPS 140-2].

- Root CAs SHALL perform all CA cryptographic operations on cryptographic modules rated at a minimum of FIPS 140-2 level 3 or higher.

- Sub-CAs SHALL use a FIPS 140-2 Level 3 or higher validated hardware cryptographic module.
- Subscribers SHOULD use a FIPS 140-2 Level 1 or higher validated cryptographic module for their cryptographic operations.
- Subscribers of CBSD certificates SHALL secure keying material as defined in the WinnForum ComSec specification.

6.2.2 *Private Key (m out of n) Multi-Person Control*

Multi-person control is enforced to protect the activation data needed to activate CA private keys so that a single person SHALL not be permitted to activate or access any cryptographic module that contains the complete CA private signing key.

CA signature keys SHOULD be backed up only under multi-person control. Access to CA signing keys backed up for disaster recovery SHALL be under multi-person control. The names of the parties used for multi-person control SHALL be maintained on a list that SHALL be made available for inspection during compliance audits.

CAs MAY use “Secret Sharing” to split the private key or activation data needed to operate the private key into separate parts called “Secret Shares” held by individuals called “Shareholders.” Some threshold number of Secret Shares (m) out of the total number of Secret Shares (n) SHALL be required to operate the private key. The minimum threshold number of shares (m) needed to sign a CA certificate SHALL be 3. The total number of shares (n) used SHALL be greater than the minimum threshold number of shares (m).

CAs MAY also use Secret Sharing to protect the activation data needed to activate private keys located at their respective disaster recovery sites. The minimum threshold number of shares (m) needed to sign a CA certificate at a disaster recovery site SHALL be 3. The total number of shares (n) used SHALL be greater than the minimum threshold number of shares (m).

6.2.3 *Private Key Escrow*

CA private keys and Subscriber private keys SHALL NOT be escrowed.

6.2.4 *Private Key Backup*

CAs SHALL back up their private keys, under the same multi-person control as the original signature key. The backups allow the CA to be able to recover from disasters and equipment malfunction. At least one copy of the private signature key SHALL be stored off-site. Private keys that are backed up SHALL be protected from unauthorized modification or disclosure through physical or cryptographic means. Backups, including all activation data needed to activate the cryptographic token containing the private key, SHALL be protected with a level of physical and cryptographic protection equal to or exceeding that for cryptographic modules within the CA site, such as at a disaster recovery site or at another secure off-site facility, such as a bank safe. All copies of the CA private signature key SHALL be accounted for and protected in the same manner as the original.

Device private keys MAY be backed up or copied, but SHALL be held under the control of the Subscriber or other authorized administrator. Backed up device private keys SHALL NOT be stored in plaintext form and storage SHALL ensure security controls consistent with the WInnForum security specifications the device is compliant with. Subscribers MAY have the option of using enhanced private key protection mechanisms available today including the use of smart cards, biometric access devices, and other hardware tokens to store private keys.

6.2.5 Private Key Archival

CA private keys and Subscriber private keys SHALL NOT be archived. Upon expiration of a CA Certificate, the key pair associated with the certificate will be securely retained for a period of at least 5 years using hardware cryptographic modules that meet the requirements of this CP. These CA key pairs SHALL NOT be used for any signing events after the expiration date of the corresponding CA Certificate, unless the CA Certificate has been renewed in terms of this CP.

6.2.6 Private Key Transfer into or from a Cryptographic Module

CA private keys MAY be exported from the cryptographic module only to perform CA key backup procedures as described in CP § 6.2.4. At no time shall the CA private key exist in plaintext outside the cryptographic module.

All other keys SHALL be generated by and in a cryptographic module. In the event that a private key is to be transported from one cryptographic module to another, the private key SHALL be encrypted during transport; private keys SHALL never exist in plaintext form outside the cryptographic module boundary.

Private or symmetric keys used to encrypt other private keys for transport SHALL be protected from disclosure.

Entry of a private key into a cryptographic module SHALL use mechanisms to prevent loss, theft, modification, unauthorized disclosure, or unauthorized use of such private key.

Processing Centers generating CA or RA private keys on one hardware cryptographic module and transferring them into another shall securely transfer such private keys into the second cryptographic module to the extent necessary to prevent loss, theft, modification, unauthorized disclosure, or unauthorized use of such private keys. Such transfers shall be limited to making backup copies of the private keys on tokens.

CAs pre-generating private keys and transferring them into a hardware token, for example transferring generated end-user Subscriber private keys into a smart card, SHALL securely transfer such private keys into the token to the extent necessary to prevent loss, theft, modification, unauthorized disclosure, or unauthorized use of such private keys.

6.2.7 Private Key Storage on Cryptographic Module

No stipulation beyond that specified in FIPS 140-2.

6.2.8 *Method of Activating Private Key*

All CAs SHALL protect the activation data for their private keys against loss, theft, modification, disclosure, or unauthorized use.

CA administrators SHALL be authenticated to the cryptographic token before the activation of the associated private key(s). Acceptable means of authentication include but are not limited to passphrases, PINs or biometrics. Entry of activation data SHALL be protected from disclosure (i.e., the data should not be displayed while it is entered).

For device certificates, the device MAY be configured to activate its private key, provided that appropriate physical and logical access controls are implemented for the device. The strength of the security controls SHALL be commensurate with the level of threat in the device's environment, and SHALL protect the device's hardware, software, private keys and its activation data from compromise.

CA Administrator Activation

Method of activating the CA system by a CA Administrator SHALL require:

- Use a smart card, biometric access device, password in accordance with CP § 6.4.1, or security of equivalent strength to authenticate the Administrator before the activation of the private key, which includes, for instance, a password to operate the private key, a Windows logon or screen saver password, or a network logon password; and
- Take commercially reasonable measures for the physical protection of the Administrator's workstation to prevent use of the workstation and its associated private key without the Administrator's authorization.

Offline Root CAs Private Key

Once the CA system has been activated, a threshold number of Shareholders SHALL be required to supply their activation data in order to activate an offline CA's private key, as defined in CP § 6.2.2. Once the private key is activated, it SHALL be active until termination of the session.

Online Subordinate CAs Private Keys

An online CA's private key SHALL be activated by a threshold number of Shareholders, as defined in CP § 6.2.2, supplying their activation data (stored on secure media). Once the private key is activated, the private key may be active for an indefinite period until it is deactivated when the CA goes offline.

Subscriber Private Keys

The WinnForum standards for protecting activation data for Subscribers' private keys SHALL be in accordance with the specific obligations appearing in the applicable agreement executed between WinnForum and the Subscriber.

6.2.9 *Method of Deactivating Private Key*

Cryptographic modules that have been activated SHALL NOT be available to unauthorized access. After use, the cryptographic module SHALL be deactivated, e.g., via a manual logout procedure

or automatically after a period of inactivity. CA cryptographic modules SHALL be stored securely when not in use.

When an online CA is taken offline, the CA SHALL remove the token containing the private key from the reader in order to deactivate it, or take similar action based upon the type of hardware used to store the private key.

With respect to the private keys of offline CAs, after the completion of a Key Generation Ceremony, in which such private keys are used for private key operations, the CA SHALL remove the token containing the private keys from the reader in order to deactivate them, or take similar action based upon the type of hardware used to store the private key. Once removed from the reader, tokens SHALL be securely stored.

When an online CA is taken offline, the CA SHALL remove the token containing such CA's private key from the reader in order to deactivate it.

When deactivated, private keys SHALL be kept in encrypted form only.

6.2.10 Method of Destroying Private Key

Private keys SHALL be destroyed in a way that prevents their theft, disclosure, or unauthorized use.

Upon termination of the operations of a CA, individuals in trusted roles SHALL decommission the CA private signature keys by deleting it using functionality of the token containing such CA's private key so as to prevent its recovery following deletion, or the loss, theft, modification, disclosure, or unauthorized use of such private key. CA private keys SHALL be destroyed in a manner that reasonably ensures that there are no residuals remains of the key that could lead to the reconstruction of the key.

For Root CAs, WinnForum security personnel SHALL witness this process.

Subscribers MAY destroy their private signature keys when they are no longer needed or when the certificates to which they correspond expire or are revoked. Physical destruction of hardware is not required.

6.2.11 Cryptographic Module Rating

See CP § 6.2.1.

6.3 Other Aspects of Key Pair Management

6.3.1 Public Key Archival

CAs MAY archive their public keys in accordance with CP § 5.5.1.

6.3.2 *Certificate Operational Periods and Key Pair Usage Periods*

The certificate validity period (i.e., certificate operational period and key pair usage period) SHALL be set to the time limits set forth as follows:

- Root CA certificates MAY have a validity period of up to 50 years
- Sub-CA certificates MAY have a validity period of up to 30 years
- Subscriber certificates MAY have a validity period of up to 20 years

Validity periods SHALL be nested such that the validity periods of issued certificates SHALL be contained within the validity period of the issuing CA.

As necessary to ensure the continuity and security of the CBRS PKI, WinnForum SHALL commission new CAs.

CBRS PKI Participants SHALL cease all use of their key pairs after their usage periods have expired.

6.4 **Activation data**

6.4.1 *Activation Data Generation and Installation*

CAs SHALL generate and installing activation data for their private keys and SHALL use methods that protect the activation data to the extent necessary to prevent the loss, theft, modification, disclosure, or unauthorized use of such activation data.

To the extent passwords are used as activation data, CAs activation participants SHALL generate passwords that cannot easily be guessed or cracked by dictionary attacks. Participants may not need to generate activation data, for example if they use biometric access devices.

6.4.2 *Activation Data Protection*

CAs SHALL protect the activation data for their private keys using methods that protect against the loss, theft, modification, unauthorized disclosure, or unauthorized use of such private keys.

CAs SHALL use multi-party control in accordance with CP § 6.2.2. CAs SHALL provide the procedures and means to enable Shareholders to take the precautions necessary to prevent the loss, theft, modification, disclosure, or unauthorized use of the Secret Shares that they possess. Shareholders SHALL not:

- Copy, disclose, or make the Secret Share available to a third party, or make any unauthorized use of it whatsoever; or
- Disclose their or any other person's status as a Shareholder to any third party.

The Secret Shares and any information disclosed to the Shareholder in connection with their duties as a Shareholder SHALL constitute Confidential/Private Information.

CAs SHALL include in their disaster recovery plans provisions for making Secret Shares available at a disaster recovery site after a disaster (Note, the important aspect of disaster recovery vis-à-vis

shares is that a process exists for making the necessary number of shares available, even if the requisite shareholders are not available.). CAs SHALL maintain an audit trail of Secret Shares, and Shareholders SHALL participate in the maintenance of an audit trail.

6.4.3 *Other Aspects of Activation Data*

Activation Data Transmission

To the extent activation data for their private keys are transmitted, Activation Data Participants SHALL protect the transmission using methods that protect against the loss, theft, modification, unauthorized disclosure, or unauthorized use of such private keys. To the extent desktop computer or network logon user name/password combination is used as activation data for an end-user Subscriber, the passwords transferred across a network SHALL be protected against access by unauthorized users.

Activation Data Destruction

Activation data for CA private keys SHALL be decommissioned using methods that protect against the loss, theft, modification, unauthorized disclosure, or unauthorized use of the private keys protected by such activation data. After the record retention periods in CP § 5.5.2 lapses, CAs SHALL decommission activation data by overwriting and/or physical destruction.

6.5 Computer security controls

6.5.1 *Specific Computer Security Technical Requirements*

CAs SHALL ensure that the systems maintaining CA software and data files are Trustworthy Systems secure from unauthorized access, which can be demonstrated by compliance with audit criteria applicable under CP § 5.4.1. In addition, CAs SHALL limit access to production servers to those individuals with a valid business reason for access. General application users SHALL not have accounts on the production servers.

CAs SHALL have production networks logically separated from other components. This separation prevents network access except through defined application processes. CAs SHALL use firewalls to protect the production network from internal and external intrusion and limit the nature and source of network activities that may access production systems.

To the extent that passwords are used, CAs SHALL require the use of passwords with a minimum character length and a combination of alphanumeric and special characters, and SHALL require that passwords be changed on a periodic basis and whenever necessary. Direct access to a CA's database maintaining the CA's repository SHALL be limited to Trusted Persons having a valid business reason for such access.

Computer security controls are required to ensure CA operations are performed as specified in this policy. The following computer security functions MAY be provided by the operating system, or through a combination of operating system, software, and physical safeguards:

- Require authenticated logins

- Provide discretionary access control
- Provide a security audit capability
- Enforce access control for CA services and PKI roles
- Enforce separation of duties for PKI roles
- Require identification and authentication of PKI roles and associated identities
- Prohibit object reuse or require separation for CA random access memory
- Require use of cryptography for session communication and database security
- Archive CA history and audit data
- Require self-test security-related CA services
- Require a trusted path for identification of PKI roles and associated identities
- Require a recovery mechanism for keys and the CA system
- Enforce domain integrity boundaries for security-critical processes.

For other CAs operating under this policy, the computer security functions listed below are required. These functions MAY be provided by the operating system, or through a combination of operating system, software, and physical safeguards. The CA and its ancillary parts SHALL include the following functionality:

- Authenticate the identity of users before permitting access to the system or applications;
- Manage privileges of users to limit users to their assigned roles;
- Generate and archive audit records for all transactions; (see CP § 5.4)
- Enforce domain integrity boundaries for security critical processes; and
- Support recovery from key or system failure.

For certificate status servers operating under this policy, the computer security functions listed below are required:

- Authenticate the identity of users before permitting access to the system or applications;
- Manage privileges of users to limit users to their assigned roles;
- Enforce domain integrity boundaries for security critical processes; and
- Support recovery from key or system failure.

For remote workstations used to administer the CAs, the computer security functions listed below are required:

- Authenticate the identity of users before permitting access to the system or applications;
- Manage privileges of users to limit users to their assigned roles;
- Generate and archive audit records for all transactions; (see CP § 5.4)
- Enforce domain integrity boundaries for security critical processes; and
- Support recovery from key or system failure.

All communications between any PKI trusted role and the CA SHALL be authenticated and protected from modification.

6.5.2 Computer Security Rating

No Stipulation.

6.6 Life Cycle Technical Controls

6.6.1 System Development Controls

- The system development controls for the CA are as follows:
- The CA SHALL use software that has been designed and developed under a formal, documented development methodology.
- Hardware and software procured to operate the CA SHALL be purchased in a fashion to reduce the likelihood that any particular component was tampered with (e.g., by ensuring the vendor cannot identify the PKI component that will be installed on a particular device).
- Hardware and software developed specifically for the CA SHALL be developed in a controlled environment, and the development process SHALL be defined and documented. This requirement does not apply to commercial off-the-shelf hardware or software.
- The CA hardware and software SHALL be dedicated to performing one task: the CA. There shall be no other applications, hardware devices, network connections, or component software installed that are not parts of the CA operation. Where the CA operation supports multiple CAs, the hardware platform MAY support multiple CAs.
- Proper care SHALL be taken to prevent malicious software from being loaded onto the CA equipment. All applications required to perform the operation of the CA SHALL be obtained from documented sources.
- Hardware and software updates SHALL be purchased or developed in the same manner as the corresponding original equipment, and SHALL be installed by trusted and trained personnel in a defined manner.

6.6.2 Security Management Controls

The configuration of the CA system, in addition to any modifications and upgrades, SHALL be documented and controlled. There SHALL be a mechanism for detecting unauthorized modification to the software or configuration. The CA software, when first loaded, SHALL be verified as being that supplied from the vendor, with no modifications, and be the version intended for use.

6.6.3 Life Cycle Security Controls

No Stipulation.

6.7 Network Security Controls

A network guard, firewall, or filtering router SHALL protect network access to CA equipment. The network guard, firewall, or filtering router SHALL limit services allowed to and from the CA equipment to those required to perform CA functions.

Protection of CA equipment SHALL be provided against known network attacks. All unused network ports and services SHALL be turned off. Any network software present on the CA equipment SHALL be necessary to the functioning of the CA application.

Any boundary control devices used to protect the network on which PKI equipment is hosted SHALL deny all but the necessary services to the PKI equipment.

Repositories, certificate status servers, and remote workstations used to administer the CAs SHALL employ appropriate network security controls. Networking equipment SHALL turn off unused network ports and services. Any network software present SHALL be necessary to the functioning of the equipment.

The CA SHALL establish connection with a remote workstation used to administer the CA only after successful authentication of the remote workstation at a level of assurance commensurate with that of the CA.

6.8 Time-Stamping

Certificates, CRLs, and other revocation database entries SHALL contain time and date information. Such time information need not be cryptographic-based. Asserted times SHALL be accurate to within three minutes. Electronic or manual procedures MAY be used to maintain system time. Clock adjustments are auditable events (see CP § 5.4.1).

7 Certificate, CRL, and OCSP Profiles

7.1 Certificate Profile

CBRS PKI Certificates SHALL conform to [RFC 5280]: Internet X.509 Public Key Infrastructure Certificate and Certificate Revocation List (CRL) Profile, May 2008. Text fields are encoded using utf8String encoding.

CBRS PKI Certificates SHALL contain the identity and attribute data of a subject using the base certificate with applicable extensions. The base certificate SHALL contain the version number of the certificate, the certificate’s identifying serial number, the signature algorithm used to sign the certificate, the issuer’s distinguished name, the validity period of the certificate, the subject’s distinguished name, information about the subject’s public key, and extensions as defined in the following certificate profile tables.

CBRS PKI Certificates MAY be used in testing environments if they meet the following requirements for “Test Certificates”. Test certificates SHALL contain the WInnForum Poison extension (OID 1.3.6.1.4.1.46609.1.999). If included in a certificate, the WInnForum Poison extension SHALL be marked Critical and its extnValue OCTET STRING SHALL contain only ASN.1 NULL data (0x05 0x00).

Table 4: RSA Root CA Certificate Profile

Version	v3
Serial number	Unique Positive Integer in the context of the issuing Root CA and not longer than 20 octets.
Issuer DN	c=US o=WInnForum ou=RSA Root CA<ID#> cn=WInnForum RSA Root CA
Subject DN	c=US o=WInnForum

Version		v3		
		ou=RSA Root CA<ID#> cn=WinnForum RSA Root CA		
Validity Period		50 yrs		
Signature		Sha384WithRSAEncryption (1.2.840.113549.1.1.12) or, Sha512WithRSAEncryption (1.2.840.113549.1.1.13)		
Subject Public Key Info algorithm keysize parameters		RSA (1.2.840.113549.1.1.1) 4096-bits NULL		
Extensions	OID	Include	Criticality	Value
keyUsage	{id-ce 15}	X	TRUE	
keyCertSign				Set
cRLSign				Set
basicConstraints	{id-ce 19}	X	TRUE	
cA				Set
pathLenConstraint				Not set
subjectKeyIdentifier	{id-ce 14}	X	FALSE	
keyIdentifier				Calculated per Method 1
subjectAltName	{id-ce 17}	O	FALSE	

<ID#> indicates the ID number of the Root and is populated when the Root CA certificate is issued. For Example, "RSA Root CA0001."

Table 5: RSA Sub-CA Certificate Profile

Version	v3
Serial number	Unique Positive Integer in the context of the issuing Root CA and not longer than 20 octets.
Issuer DN	c=US o=WinnForum ou=RSA Root CA<ID#> cn=WinnForum RSA Root CA
Subject DN	c=<Country Code> o=<Organization Name> ou=RSA <Sub-CA Type> <ID#> <i>or</i> RSA <Sub-CA Type> <ID#> cn=WinnForum RSA <Sub-CA Type> <i>or</i> WinnForum RSA <Sub-CA Type>
Validity Period	30 yrs
Signature	Sha384WithRSAEncryption (1.2.840.113549.1.1.12) <i>or</i> ,

Version		v3		
		Sha512WithRSAEncryption (1.2.840.113549.1.1.13)		
Subject Public Key Info algorithm keysize parameters		RSA (1.2.840.113549.1.1.1) 4096-bits NULL		
Extensions	OID	Include	Criticality	Value
keyUsage	{id-ce 15}	X	TRUE	
keyCertSign				Set
cRLSign				Set
basicConstraints	{id-ce 19}	X	TRUE	
cA				Set
pathLenConstraint				0 (zero) or not set for CBSD OEM sub-CA 1 (one) for CBSD Manufacturer sub-CA
subjectKeyIdentifier	{id-ce 14}	X	FALSE	
keyIdentifier				Calculated per Method 1
authorityKeyIdentifier	{id-ce 35}	X	FALSE	
keyIdentifier				Calculated per Method 1
subjectAltName	{id-ce 17}	O	FALSE	
certificatePolicies	{id-ce 32}	X	FALSE	
certPolicyId	1.3.6.1.4.1.46609.2.1			
policyQualifiers				Not set
certPolicyId	1.3.6.1.4.1.46609.1.1.5			
certPolicyId	<CBRS PKI Role OID>			

<Sub-CA Type> is one of the following values not including the quotes: “CBSD Mfr CA”, “CBSD OEM CA”, “SAS Provider CA”, “Domain Proxy CA”, “Professional Installer CA”, “PAL CA”.

<ID#> indicates the ID number of the CA and is populated when the CA certificate is issued. For Example, “CA0001.”

<CBRS PKI Role OID> is a value identified in Section 1.2, “Table 1: WinnForum OID Arcs”

Table 6: RSA Subscriber Certificate Profile

Version	v3
Serial number	Unique Positive Integer in the context of the issuing CA and not longer than 20 octets.
Issuer DN	c=<Country Code> o=<Organization Name> ou=RSA <Sub-CA Type> <ID#> or RSA <Sub-CA Type> <ID#>

Version		v3		
		cn=WinnForum RSA <Sub-CA Type> <i>or</i> WinnForum RSA <Sub-CA Type>		
Subject DN		c=<Country Code> o=<Organization Name> ou=WinnForum <Device Type> Certificate cn=<Device Identifier>		
Validity Period		15 months for SAS Provider and Domain Proxy 27 months for Installer 10 years for CBSD		
Signature		Sha256WithRSAEncryption (1.2.840.113549.1.1.11) <i>or</i> , Sha384WithRSAEncryption (1.2.840.113549.1.1.12) <i>or</i> , Sha512WithRSAEncryption (1.2.840.113549.1.1.13)		
Subject Public Key Info algorithm keysize parameters		RSA (1.2.840.113549.1.1.1) 2048-bits NULL		
Extensions	OID	Include	Criticality	Value
keyUsage	{id-ce 15}	X	TRUE	
digitalSignature				Set
keyEncipherment				Set
subjectKeyIdentifier	{id-ce 14}	X	FALSE	
keyIdentifier				Calculated per Method 1 as defined in X509 standard (RFC 5280)
authorityKeyIdentifier	{id-ce 35}	X	FALSE	
keyIdentifier				Calculated per Method 1 as defined in X509 standard (RFC 5280)
subjectAltName	{id-ce 17}	O	FALSE	
otherName	<SAN Device Identifier OID>			<Device Identifier>
dNSName	{id-ce 17.2}			<SAS FQDN>
certificatePolicies	{id-ce 32}	X	FALSE	
certPolicyId	1.3.6.1.4.1.46609.2.1			
policyQualifiers				Not set
certPolicyId	1.3.6.1.4.1.46609.1.1.5			
certPolicyId	<CBRS PKI Role OID>			
extKeyUsage		O	FALSE	
cRLDistributionPoint		O	FALSE	

<Sub-CA Type> is one of the following values not including the quotes: “CBSD Mfr CA”, “CBSD OEM CA”, “SAS Provider CA”, “Domain Proxy CA”, “Professional Installer CA”, “PAL CA”.

<ID#> indicates the ID number of the CA and is populated when the CA certificate is issued. For Example, “CA0001.”

<Device Type> is one of the following values not including the quotes: “SAS Provider”, “Domain Proxy”, “Installer”, “PAL”, “Secondary Market PAL”, “CBSD”.

<Device Identifier> is one of the following values:

For CBSD device certificates – <FCC ID>:<device serial number>, e.g. 0014720239:234A65760123

For Domain Proxy - <FRN of certified Domain Proxy>:<unique identifier chosen by owner of FRN>

For SAS Provider certificates – Fully qualified domain name (FQDN) of SAS provider server

For Installer certificates – Unique identifier (CPIR-ID) issued by the CPI training program

<SAS FQDN> is the fully qualified domain name (FQDN) of the SAS provider server

<SAN Device Identifier OID> is one of the following values:

For CBSD device certificates - 1.3.6.1.4.1.46609.1.4 is used for the <FCC ID> value and 1.3.6.1.4.1.46609.1.5 is used for the <Device Serial Number> value.

For Domain Proxy - 1.3.6.1.4.1.46609.1.6

For SAS Provider certificates - 1.3.6.1.4.1.46609.1.6

For Installer certificates - 1.3.6.1.4.1.46609.1.7

<CBRS PKI Role OID> is a value identified in Section 1.2, “Table 1: WinnForum OID Arcs”

Table 7: ECC Root CA Certificate Profile

Version	v3			
Serial number	Unique Positive Integer in the context of the issuing Root CA and not longer than 20 octets.			
Issuer DN	c=US o=WinnForum ou=ECC Root CA<ID#> cn=WinnForum ECC Root CA			
Subject DN	c=US o=WinnForum ou=ECC Root CA<ID#> cn=WinnForum ECC Root CA			
Validity Period	50 yrs			
Signature	ecdsa-with-Sha384 (1.2.840.10045.4.3.3) or, ecdsa-with-Sha512 (1.2.840.10045.4.3.4)			
Subject Public Key Info algorithm parameters	EC (1.2.840.10045.2.1) Secp384r1 (1.2.840.10045.3.1.34) or Secp521r1 (1.2.840.10045.3.1.35)			
Extensions	OID	Include	Criticality	Value
keyUsage	{id-ce 15}	X	TRUE	
keyCertSign				Set
cRLSign				Set

Version		v3		
basicConstraints	{id-ce 19}	X	TRUE	
cA				Set
pathLenConstraint				Not set
subjectKeyIdentifier	{id-ce 14}	X	FALSE	
keyIdentifier				Calculated per Method 1
subjectAltName	{id-ce 17}	O	FALSE	

<ID#> indicates the ID number of the Root and is populated when the Root CA certificate is issued. For Example, "ECC Root CA0001."

Table 8: ECC Sub-CA Certificate Profile

Version		v3		
Serial number		Unique Positive Integer in the context of the issuing Root CA and not longer than 20 octets.		
Issuer DN		c=US o=WinnForum ou=ECC Root CA<ID#> cn=WinnForum ECC Root CA		
Subject DN		c=<Country Code> o=<Organization Name> ou=ECC <Sub-CA Type> <ID#> or ECC <Sub-CA Type> <ID#> cn=WinnForum ECC <Sub-CA Type> or WinnForum ECC <Sub-CA Type>		
Validity Period		30 yrs		
Signature		ecdsa-with-Sha384 (1.2.840.10045.4.3.3) or, ecdsa-with-Sha512 (1.2.840.10045.4.3.4)		
Subject Public Key Info algorithm parameters		EC (1.2.840.10045.2.1) Secp384r1 (1.2.840.10045.3.1.34) or Secp521r1 (1.2.840.10045.3.1.35)		
Extensions	OID	Include	Criticality	Value
keyUsage	{id-ce 15}	X	TRUE	
keyCertSign				Set
cRLSign				Set
basicConstraints	{id-ce 19}	X	TRUE	
cA				Set
pathLenConstraint				0 (zero) or not set for CBSD OEM sub-CA 1 (one) for CBSD Manufacturer sub-CA
subjectKeyIdentifier	{id-ce 14}	X	FALSE	
keyIdentifier				Calculated per Method 1

Version		v3		
authorityKeyIdentifier	{id-ce 35}	X	FALSE	
keyIdentifier				Calculated per Method 1
subjectAltName	{id-ce 17}	O	FALSE	
certificatePolicies	{id-ce 32}	X	FALSE	
certPolicyId	1.3.6.1.4.1.46609.2.1			
policyQualifiers				Not set
certPolicyId	1.3.6.1.4.1.46609.1.1.5			
certPolicyId	<CBRS PKI Role OID>			

<Sub-CA Type> is one of the following values not including the quotes: “CBSD Mfr CA”, “CBSD OEM CA”, “SAS Provider CA”, “Domain Proxy CA”, “Professional Installer CA”, “PAL CA”.

<ID#> indicates the ID number of the CA and is populated when the CA certificate is issued. For Example, “CA0001.”

<CBRS PKI Role OID> is a value identified in Section 1.2, “Table 1: WinnForum OID Arcs”

Table 9: ECC Subscriber Certificate Profile

Version	v3			
Serial number	Unique Positive Integer in the context of the issuing CA and not longer than 20 octets.			
Issuer DN	c=<Country Code> o=<Organization Name> ou=ECC <Sub-CA Type> <ID#> or ECC <Sub-CA Type> <ID#> cn=WinnForum ECC <Sub-CA Type> or WinnForum ECC <Sub-CA Type>			
Subject DN	c=<Country Code> o=<Organization Name> ou=WinnForum <Device Type> Certificate cn=<Device Identifier>			
Validity Period	15 months for SAS Provider and Domain Proxy 27 months for Installer 10 years for CBSD			
Signature	ecdsa-with-Sha256 (1.2.840.10045.4.3.2) or, ecdsa-with-Sha384 (1.2.840.10045.4.3.3) or, ecdsa-with-Sha512 (1.2.840.10045.4.3.4)			
Subject Public Key Info algorithm parameters	EC (1.2.840.10045.2.1) Secp256r1 (1.2.840.10045.3.1.7) or Secp384r1 (1.2.840.10045.3.1.34) or Secp521r1 (1.2.840.10045.3.1.35)			
Extensions	OID	Include	Criticality	Value
keyUsage	{id-ce 15}	X	TRUE	
digitalSignature				Set

Version	v3			
keyAgreement				Set
subjectKeyIdentifier	{id-ce 14}	X	FALSE	
keyIdentifier				Calculated per Method 1 as defined in X509 standard (RFC 5280)
authorityKeyIdentifier	{id-ce 35}	X	FALSE	
keyIdentifier				Calculated per Method 1 as defined in X509 standard (RFC 5280)
subjectAltName	{id-ce 17}	O	FALSE	
otherName	<SAN Device Identifier OID>			<Device Identifier>
dnsName	{id-ce 17.2}			<SAS FQDN>
certificatePolicies	{id-ce 32}	X	FALSE	
certPolicyId	1.3.6.1.4.1.46609.2.1			
policyQualifiers				Not set
certPolicyId	1.3.6.1.4.1.46609.1.1.5			
certPolicyId	<CBRS PKI Role OID>			
extKeyUsage		O	FALSE	
cRLDistributionPoint		O	FALSE	

<Sub-CA Type> is one of the following values not including the quotes: “CBSD Mfr CA”, “CBSD OEM CA”, “SAS Provider CA”, “Domain Proxy CA”, “Professional Installer CA”, “PAL CA”.

<ID#> indicates the ID number of the CA and is populated when the CA certificate is issued. For Example, “CA0001.”

<Device Type> is one of the following values not including the quotes: “SAS Provider”, “Domain Proxy”, “Installer”, “PAL”, “Secondary Market PAL”, “CBSD”.

<Device Identifier> is one of the following values:

For CBSD device certificates – <FCC ID>:<device serial number>, e.g. [0014720239](#):234A65760123

For Domain Proxy - <FRN of certified Domain Proxy>:<unique identifier chosen by owner of FRN>

For SAS Provider certificates – Fully qualified domain name (FQDN) of SAS provider server

For Installer certificates – Unique identifier (CPIR-ID) issued by the CPI training program

<SAS FQDN> is the fully qualified domain name (FQDN) of the SAS provider server

<SAN Device Identifier OID> is one of the following values:

For CBSD device certificates - 1.3.6.1.4.1.46609.1.4 is used for the <FCC ID> value and 1.3.6.1.4.1.46609.1.5 is used for the <Device Serial Number> value.

For Domain Proxy - 1.3.6.1.4.1.46609.1.6

For SAS Provider certificates - 1.3.6.1.4.1.46609.1.6

For Installer certificates - 1.3.6.1.4.1.46609.1.7

<CBRS PKI Role OID> is a value identified in Section 1.2, “Table 1: WInnForum OID Arcs”

7.2 CRL Profile

CRLs SHALL conform to [RFC 5280] and contain the basic fields and contents specified in the table below:

Table 10: CRL Profile Basic Fields

Field	Referenced Standard	Section	Requirement or Recommendation
version	[RFC 5280]	5.1.2.1	See Section 7.2.1.
signature	[RFC 5280]		Algorithm used to sign the CRL.
issuer	[RFC 5280]	5.1.2.3	Entity that has signed and issued the CRL.
thisUpdate	[RFC 5280]	5.1.2.4	Indicates the issue date of the CRL. CRLs are effective upon issuance.
nextUpdate	[RFC 5280]	5.1.2.5	Indicates the date by which the next CRL will be issued.
revokedCertificates	[RFC 5280]	5.1.2.6	Listing of revoked certificates, including the Serial Number of the revoked Certificate and the Revocation Date.
authorityKeyIdentifier	[RFC 5280]	5.2.1	Follows the guidance in RFC 5280. Criticality is FALSE.
cRLNumber	[RFC 5280]	5.2.3	A monotonically increasing sequence number for a given CRL scope and issuer. Criticality is FALSE.
signatureAlgorithm	[RFC 5280]	5.1.1.2	Follows the guidance in RFC 5280.
signatureValue	[RFC 5280]	5.1.1.3	Follows the guidance in RFC 5280.

7.2.1 Version Number(s)

The CAs SHALL support the issuance of X.509 Version two (2) CRLs. The CRL version number SHALL be set to the integer value of "1" for Version 2 [RFC 5280, section 5.1.2.1].

7.2.2 CRL and CRL entry extensions

Critical CRL extensions SHALL NOT be used.

7.3 OCSP Profile

OCSP (Online Certificate Status Protocol) is optional but is a way to obtain timely information about the revocation status of a particular certificate. OCSP Responses SHALL conform to [RFC5019] and SHALL either be:

- Signed by the CA that issued the Certificates whose revocation status is being checked, or
- Signed by an OCSP Responder whose Certificate is signed by the CA that issued the Certificate whose revocation status is being checked. Such OCSP Responder signing Certificate SHALL contain the extension id-pkix-ocsp-nocheck as defined by [RFC2560].

7.3.1 *Version Number(s)*

OCSP responses SHALL support use of OCSP version 1 as defined by [RFC2560] and [RFC5019].

7.3.2 *OCSP Extensions*

Critical OCSP extensions SHALL NOT be used.

8 Compliance Audit and Other Assessments

8.1 Frequency or Circumstances of Assessment

CAs operating under this policy SHALL be subject to a periodic compliance audit at least once per year. Compliance Audits are conducted at the sole expense of the audited entity. The WinnForum MAY require a periodic compliance audit report of CAs operating under this policy as stated in CP § 8.4.

8.2 Identity/Qualifications of Assessor

The CA MAY select an auditor, subject to the qualifications described herein. The auditor SHALL demonstrate competence in the field of compliance audits, and SHALL be thoroughly familiar with the CA's CPS and this CP. The auditor SHALL be a certified information system auditor (CISA), or IT security specialist, and a PKI subject matter specialist who can offer input regarding acceptable risks, mitigation strategies, and industry best practices.

Audits performed by an independent third party audit firm SHALL be performed by a certified public accounting firm with demonstrated expertise in computer security or by accredited computer security professionals employed by a competent security consultancy. Such firm SHALL also have demonstrated expertise in the performance of IT security and PKI compliance audits.

The qualified audit firm SHALL be bound by law, government regulation, or professional code of ethics and SHALL maintain Professional Liability/Errors & Omissions insurance with policy limits of at least one million US dollars in coverage.

8.3 Assessor's Relationship to Assessed Entity

The compliance auditor either SHALL be a private firm that is independent from the CA being audited, or it SHALL be sufficiently organizationally separated from those entities to provide an unbiased, independent evaluation. Compliance auditors SHALL not have a conflict of interest that hinders their ability to perform auditing services. To insure independence and objectivity, the compliance auditor may not have served the entity in developing or maintaining the entity's CA

Facility or CPS. The WInnForum SHALL determine whether a compliance auditor meets this requirement.

8.4 Topics Covered by Assessment

CA's SHALL perform an annual compliance audit for "WebTrust Principles and Criteria for Certification Authorities 2.0" which includes: A Report of Policies and Procedures in Operation and Test of Operational Effectiveness. The purpose of the annual compliance audit shall be to verify that a CA complies with all the mandatory requirements of the current versions of this CP and the CA's CPS.

All aspects of the CA operation SHALL be subject to the compliance audit and SHOULD address the items listed below. A WebTrust for Certification Authorities or equivalent will satisfy this requirement.

- Identify foreseeable internal and external threats that could result in unauthorized access, disclosure, misuse, alteration, or destruction of any Certificate Data or Certificate Management Processes;
- Assess the likelihood and potential damage of these threats, taking into consideration the sensitivity of the Certificate Data and Certificate Management Processes; and
- Assess the sufficiency of the policies, procedures, information systems, technology, and other arrangements that the CA has in place to counter such threats.

In addition to compliance audits, if the WInnForum has a reasonable belief that a CA is not operating in conformance with this CP, the WInnForum SHALL be entitled, to perform other reviews and investigations, which include, but are not limited to:

- A "Security and Practices Review," which consists of a review of a CA's secure facility, security documentation, CPS, and any other appropriate material to ensure that the CA meets the CP.
- An "Exigent Audit/Investigation" on CAs, including, for example, in the event the WInnForum has reason to believe that the audited entity has failed to meet the CP Standards, has experienced an incident or Compromise, or has acted or failed to act, such that the audited entity's failure, the incident or Compromise, or the act or failure to act poses an actual or potential threat to the security or integrity of the CBRS PKI.
- A "Supplemental Risk Management Reviews" on CAs following incomplete or exceptional findings in a Compliance Audit.

The WInnForum SHALL be entitled to delegate the performance of these audits, reviews, and investigations to (a) the Superior Entity of the entity being audited, reviewed, or investigated or (b) a third-party audit firm. Entities that are subject to an audit, review, or investigation SHALL provide cooperation with WInnForum and the personnel performing the audit, review, or investigation.

1.2 Actions Taken as a Result of Deficiency

When the compliance auditor finds a discrepancy between the requirements of this CP or the stipulations in the CPS and the design, operation, or maintenance of the PKI Authorities, the following actions SHALL be performed:

- The compliance auditor SHALL note the discrepancy;
- The compliance auditor SHALL notify the parties identified in CP § 8.6 of the discrepancy; and
- The party responsible for correcting the discrepancy will propose a remedy, including expected time for completion, to the parties identified in CP § 8.6.

In the event the audited entity fails to develop a corrective action plan to be implemented in a timely manner, or if the report reveals exceptions or deficiencies that the WInnForum reasonably believes poses an immediate threat to the security or integrity of the CBRS PKI, then the WInnForum:

- SHALL determine whether revocation and compromise reporting are necessary
- SHALL be entitled to suspend services to the audited entity
- If necessary, may terminate such services subject to this CP and the terms of the audited entity's contract

8.5 Communication of Results

Following any Compliance Audit, the audited entity SHALL provide the WInnForum with the Audit Compliance Report and identification of corrective measures within 30 days of completion. A special compliance audit MAY be required to confirm the implementation and effectiveness of the remedy.

9 Other Business and Legal Matters

9.1 Fees

9.1.1 Certificate Issuance or Renewal Fees

Subscribers MAY be charged a fee for the issuance, management, and renewal of certificates.

9.1.2 Certificate Access Fees

CAs SHALL not charge a fee as a condition of making a Certificate available in a repository or otherwise making Certificates available to Relying Parties.

9.1.3 Revocation or Status Information Access Fees

CAs SHALL not charge a fee as a condition of making CRLs available in a repository or otherwise available to Relying Parties.

9.1.4 Fees for Other Services

No stipulation.

9.1.5 *Refund Policy*

Refund policies SHOULD be stipulated in the appropriate agreement (e.g., Subscriber Agreement).

9.2 **Financial Responsibility**

9.2.1 *Insurance Coverage*

CBRS PKI Participants SHOULD maintain a commercially reasonable level of insurance coverage for errors and omissions, either through an errors and omissions insurance program with an insurance carrier or a self-insured retention.

9.2.2 *Other Assets*

CAs SHALL have sufficient financial resources to maintain their operations and perform their duties, and they SHALL be reasonably able to bear the risk of liability to Subscribers and Relying Parties.

9.2.3 *Insurance or Warranty Coverage for End-Entities*

No stipulation.

9.3 **Confidentiality of business information**

9.3.1 *Scope of Confidential Information*

The following Subscriber information SHALL be kept confidential and private:

- Certificate Application records
- CA application status, whether approved or disapproved
- Transactional records (both full records and the audit trail of transactions)
- Audit trail records
- Audit reports
- Contingency planning and disaster recovery plans
- Security measures controlling the operations of CA hardware and software

9.3.2 *Information not Within the Scope of Confidential Information*

CBRS PKI Participants acknowledge that Certificates, Certificate revocation and other status information, CBRS repositories, and information contained within them are not considered Confidential/Private Information. Information not expressly deemed Confidential/Private Information under CP § 9.3.1 SHALL be considered neither confidential nor private.

9.3.3 *Responsibility to Protect Confidential Information*

CBRS PKI Participants receiving private information SHALL secure it from compromise and disclosure to third parties.

9.4 Privacy of Personal Information

9.4.1 Privacy Plan

CAs SHALL have a Privacy Plan to protect personally identifying information from unauthorized disclosure.

9.4.2 Information Treated as Private

CAs acquiring services under this policy SHALL protect all Subscriber personally identifying information from unauthorized disclosure. Records of individual transactions MAY be released upon request of any subscribers involved in the transaction or their legally recognized agents. The contents of the archives maintained by CAs operating under this policy SHALL not be released except as required by law.

9.4.3 Information not Deemed Private

Information included in certificates is deemed public information and is not subject to protections outlined in section 9.4.2.

9.4.4 Responsibility to Protect Private Information

Sensitive information SHALL be stored securely, and MAY be released only in accordance with other stipulations in section 9.4.

9.4.5 Notice and Consent to Use Private Information

CAs are not required to provide any notice or obtain the consent of the Subscriber in order to release private information in accordance with other stipulations in section 9.4.

9.4.6 Disclosure Pursuant to Judicial or Administrative Process

The WinnForum or CBRS CAs SHALL not disclose private information to any third party unless authorized by this policy, required by law, government rule or regulation, or order of a court of competent jurisdiction.

9.4.7 Other Information Disclosure Circumstances

No stipulations.

9.5 Intellectual Property Rights

The WinnForum retains all Intellectual Property Rights in and to this CP.

CAs retain all Intellectual Property Rights in and to the Certificates and revocation information that they issue.

A Certificate Applicant retains all rights it has (if any) in any trademark, service mark, or trade name contained in any Certificate Application and distinguished name within any Certificate issued to such Certificate Applicant.

Private keys corresponding to Certificates of CAs and Subscribers are the property of the CAs and Subscribers that are the respective Subjects of these Certificates. Secret Shares of a CA's private key are the property of the CA, and the CA retains all Intellectual Property Right in and to such Secret Shares.

Without limiting the generality of the foregoing, WInnForum's root public keys and Certificates containing them, including all CA and Subscriber public keys and certificates containing them, are the property of the WInnForum. The WInnForum licenses software and hardware manufacturers to reproduce such public key Certificates to place copies in WInnForum compliant hardware devices or software.

9.6 Representations and Warranties

The WInnForum SHALL:

- Approve the CPS for each CA that issues certificates under this policy
- Review periodic compliance audits to ensure that CAs are operating in compliance with their approved CPSs
- Review name space control procedures to ensure that distinguished names are uniquely assigned for all certificates issued under this CP
- Revise this CP to maintain the level of assurance and operational practicality
- Publicly distribute this CP
- Coordinate modifications to this CP to ensure continued compliance by CAs operating under approved CPSs

9.6.1 CA Representations and Warranties

CAs operating under this CP SHALL warrant that:

- The CA procedures are implemented in accordance with this CP
- The CA will provide their CPS to the WInnForum, as well as any subsequent changes, for conformance assessment
- The CA operations are maintained in conformance to the stipulations of the approved CPS
- Any certificate issued is in accordance with the stipulations of this CP
- There are no material misrepresentations of fact in the Certificate known to or originating from the entities approving the Certificate Application or issuing the Certificate,
- There are no errors in the information in the Certificate that were introduced by the entities approving the Certificate Application as a result of a failure to exercise reasonable care in managing the Certificate Application,
- Their Certificates meet all material requirements of this CP and the applicable CPS, and
- The revocation of certificates in accordance with the stipulations in this CP
- Revocation services (when applicable) and use of a repository conform to all material requirements of this CP and the applicable CPS in all material aspects.

Subscriber Agreements MAY include additional representations and warranties.

9.6.2 *RA Representations and Warranties*

RAs that perform registration functions under this CP SHALL warrant that:

- The RA complies with the stipulations of this CP
- The RA complies with and maintains its operations in conformance to the stipulations of the approved CPS
- There are no material misrepresentations of fact in the Certificate known to or originating from the entities approving the Certificate Application or issuing the Certificate
- There are no errors in the information in the Certificate that were introduced by the entities approving the Certificate Application as a result of a failure to exercise reasonable care in managing the Certificate Application
- Their Certificates meet all material requirements of this CP and the applicable CPS
- Revocation services (when applicable) and use of a repository conform to all material requirements of this CP and the applicable CPS in all material aspects

Subscriber Agreements MAY include additional representations and warranties.

9.6.3 *Subscriber representations and warranties*

Subscribers SHALL sign an agreement containing the requirements the Subscriber shall meet including protection of their private keys and use of the certificates before being issued the certificates. In addition, Subscribers SHALL warrant that:

- The Subscriber SHALL abide by all the terms, conditions, and restrictions levied on the use of their private keys and certificates.
- Each digital signature created using the private key corresponding to the public key listed in the Certificate is the digital signature of the Subscriber and the Certificate has been accepted and is operational (not expired or revoked) at the time the digital signature is created
- Subscriber's private keys are protected from unauthorized use or disclosure
- All representations made by the Subscriber in the Certificate Application the Subscriber submitted are true
- All information supplied by the Subscriber and contained in the Certificate is true
- The Certificate is being used exclusively for authorized and legal purposes, consistent with all material requirements of this CP
- The Subscriber will promptly notify the appropriate CA upon suspicion of loss or compromise of their private key(s)
- The Subscriber is an end-user Subscriber and not a CA, and is not using the private key corresponding to any public key listed in the Certificate for purposes of digitally signing any Certificate (or any other format of certified public key) or CRL, as a CA or otherwise

Subscriber Agreements MAY include additional representations and warranties.

In the case of the automated process for issuance of device certificates the above duties are carried out by the person responsible of the device. For smooth manufacturing process, the tasks above are not mandatory upon acceptance of every certificate.

9.6.4 Relying Party Representations and Warranties

This CP does not specify the steps a Relying Party SHOULD take to determine whether to rely upon a certificate. The Relying Party decides, pursuant to its own policies, what steps to take. The CA merely provides the tools (i.e., certificates and CRLs) needed to perform the trust path creation, validation, and CP mappings that the Relying Party may wish to employ in its determination. Relying Parties acknowledge that they have sufficient information to make an informed decision as to the extent to which they choose to rely on the information in a Certificate, that they are solely responsible for deciding whether or not to rely on such information, and that they SHALL bear the legal consequences of their failure to perform the Relying Party obligations in terms of this CP.

9.6.5 Representations and Warranties of Other Participants

No stipulations.

9.7 Disclaimers of warranties

To the extent permitted by applicable law, Subscriber Agreements SHALL disclaim the WinnForum's and the applicable Affiliate's possible warranties, including any warranty of merchantability or fitness for a particular purpose.

9.8 Limitations of liability

The liability (and/or limitation thereof) of Subscribers SHALL be as set forth in the applicable Subscriber Agreements.

9.9 Indemnities

To the extent permitted by applicable law, Subscribers are required to indemnify CAs for:

- Falsehood or misrepresentation of fact by the Subscriber on the its Certificate Application
- Failure by the Subscriber to disclose a material fact on the Certificate Application, if the misrepresentation or omission was made negligently or with intent to deceive any party
- The Subscriber's failure to take the precautions necessary to prevent the compromise, loss, disclosure, modification, or unauthorized use of the Subscriber's private key(s)
- The Subscriber's use of a name (including that infringes upon the Intellectual Property Rights of a third party)

9.10 Term and termination

9.10.1 Term

The CP becomes effective when approved by the WinnForum. Amendments to this CP become effective upon publication. This CP has no specified term.

9.10.2 Termination

This CP as amended from time to time SHALL remain in force until it is replaced by a new version. Termination of this CP is at the discretion of the WinnForum.

9.10.3 Effect of termination and survival

Upon termination of this CP, CBRS PKI Participants are nevertheless bound by its terms for all certificates issued for the remainder of the validity periods of such certificates.

9.11 Individual notices and communications with participants

Unless otherwise specified by agreement between the parties, WinnForum participants SHALL use commercially reasonable methods to communicate with each other, taking into account the criticality and subject matter of the communication.

9.12 Amendments

9.12.1 Procedure for Amendment

The WinnForum SHALL review this CP at least once every year. Corrections, updates, or changes to this CP SHALL be made available as per CP § 9.12.2. Suggested changes to this CP SHALL be communicated to the contact in CP §1.5.2; such communication SHALL include a description of the change, a change justification, and contact information for the person requesting the change.

9.12.2 Notification Mechanism and Period

The WinnForum reserves the right to amend the CP without notification for amendments that are not material, including without limitation corrections of typographical errors, changes to URLs, and changes to contact information. The WinnForum's decision to designate amendments as material or non-material SHALL be within the WinnForum's sole discretion.

Change notices to this CP SHALL be distributed electronically to CBRS PKI Participants and observers in accordance with the WinnForum document change procedures.

9.12.3 Circumstances Under Which OID Shall be Changed

Object Identifiers (OIDs) will be changed if the WinnForum determines that a change in the CP reduces the level of assurance provided. If the WinnForum determines that a change is necessary in the OID corresponding to a Certificate policy, the amendment SHALL contain new object identifiers for the Certificate policies corresponding to each Class of Certificate. Otherwise, amendments shall not require a change in Certificate policy object identifier.

9.13 Dispute Resolution Provisions

The WinnForum SHALL facilitate the resolution between entities when conflicts arise as a result of the use of certificates issued under this policy.

9.14 Governing Law

Subject to any limits appearing in applicable law, the laws of the State of Colorado, U.S.A., SHALL govern the enforceability, construction, interpretation, and validity of this CP, irrespective of contract or other choice of law provisions and without the requirement to establish a commercial nexus in Colorado, USA. This choice of law is made to ensure uniform procedures and interpretation for all WinnForum Participants, no matter where they are located.

This governing law provision applies only to this CP. Agreements incorporating the CP by reference MAY have their own governing law provisions, provided that this CP § 9.14 governs the enforceability, construction, interpretation, and validity of the terms of the CP separate and apart from the remaining provisions of any such agreements, subject to any limitations appearing in applicable law.

9.15 Compliance with Applicable Law

This CP is subject to applicable national, state, local, and foreign laws, rules, regulations, ordinances, decrees, and orders including, but not limited to, restrictions on exporting or importing software, hardware, or technical information. All CAs operating under this policy are required to comply with applicable law.

9.16 Miscellaneous provisions

9.16.1 Entire Agreement

No Stipulation

9.16.2 Assignment

No stipulation

9.16.3 Severability

Should it be determined that one section of this CP is incorrect or invalid, the other sections of this CP shall remain in effect until the CP is updated. The process for updating this CP is described in CP § 9.12.

In the event that a clause or provision of this CP is held to be unenforceable by a court of law or other tribunal having authority, the remainder of the CP shall remain valid.

9.16.4 Enforcement (*Attorneys' fees and waiver of rights*)

No Stipulation

9.16.5 Force Majeure

To the extent permitted by applicable law, the CBRS PKI agreement (e.g., Digital Certificate Subscriber Agreements) shall include a force majeure clause protecting WInnForum and the applicable Affiliate.

9.17 Other Provisions

No Stipulation.

10 References

- RFC 2119 Key Words for use in RFCs to Indicate Requirement Level, IETF (Bradner), March 1997. <http://www.ietf.org/rfc/rfc2119.txt>
- RFC 2560 X.509 Internet Public Key Infrastructure Online Certificate Status Protocol – OCSP, IETF (Myers, Ankney, Malpani, Galperin, Adams), June 1999. <http://www.ietf.org/rfc/rfc2560.txt>
- RFC 3647 Internet X.509 PKI Certificate Policy and Certification Practices Framework, IETF (Chokhani, Ford, Sabett, Merrill, and Wu), November 2003. <http://www.ietf.org/rfc/rfc3647.txt>
- RFC 5019 The Lightweight Online Certificate Status Protocol (OCSP) Profile for High-Volume Environments, IETF (Deacon, Hurst), September 2007. <http://www.ietf.org/rfc/rfc5019.txt>
- RFC 5280 Internet X.509 PKI Certificate and Certification Revocation List (CRL) Profile, IETF (Cooper, Santesson, Farrell, Boeyen, Housley, and Polk), May 2008. <http://www.ietf.org/rfc/rfc5280.txt>
- FIPS 140-2 Security Requirements for Cryptographic Modules, FIPS 140-2, May 25, 2001. <http://csrc.nist.gov/publications/fips/fips140-2/fips1402.pdf>

11 Glossary

This specification uses the following terms:

- Audit Requirements Guide** A document that sets forth the security and audit requirements and practices for CAs.
- Certificate** A message that, at least, states a name or identifies the CA, identifies the Subscriber, contains the Subscriber’s public key, identifies the Certificate’s Validity Period, contains a Certificate serial number, and is digitally signed by the CA that issued the certificate.
- Certificate Applicant** An individual or organization that requests the issuance of a Certificate by a CA.
- Certificate Application** A request from a Certificate Applicant (or authorized agent of the Certificate Applicant) to a CA for the issuance of a Certificate.
- Certificate Chain** An ordered list of Certificates containing a Subscriber Certificate and one or more CA Certificates, which terminates in a root Certificate.

Control Objectives	Criteria that an entity SHALL meet in order to satisfy a Compliance Audit.
Certificate Policy (CP)	The principal statement of policy governing the PKI.
Certificate Revocation List (CRL)	A periodically (or exigently) issued list, digitally signed by a CA, of identified Certificates that have been revoked prior to their expiration dates. The list generally indicates the CRL issuer's name, the date of issue, the date of the next scheduled CRL issue, the revoked Certificates' serial numbers, and the specific times and reasons for revocation.
Certificate Signing Request (CSR)	A message conveying a request to have a Certificate issued.
Certification Authority (CA)	Authority An entity authorized to issue, manage, revoke, and renew Certificates in the PKI.
Certification Statement (CPS)	Practice A statement of the practices that a CA employs in approving or rejecting Certificate Applications and issuing, managing, and revoking Certificates.
Certificate Account (CRA)	Requesting The online portal to assist Certificate Applicants in requesting Certificates.
Compliance Audit	A periodic audit that a CA system undergoes to determine its conformance with PKI requirements that apply to it.
Compromise	A violation of a security policy, in which an unauthorized disclosure of, or loss of control over, sensitive information has occurred. With respect to private keys, a Compromise is a loss, theft, disclosure, modification, unauthorized use, or other compromise of the security of such private key.
CRL Usage Agreement	An agreement setting forth the terms and conditions under which a CRL or the information in it can be used.
Device Certificate	An end-entity non-CA certificate of the PKI chain installed in CBRS devices such as SAS Provider, Domain Proxy,
Exigent Audit/Investigation	Installer, PAL and CBSD devices, An audit or investigation by where there is reason to believe that an entity's failure to meet PKI Standards, an incident or Compromise relating to the entity, or an actual or potential threat to the security of the PKI posed by the entity has occurred.
Elliptic Cryptography (ECC)	Curve A public-key cryptography system based on the algebraic structure of elliptic curves over finite fields.
Intellectual Property Rights	Rights under one or more of the following: copyright, patent, trade secret, trademark, or any other intellectual property rights.
Key Generation Ceremony	A procedure whereby a CA's key pair is generated, its private key is backed up, and/or its public key is certified.
PKI Participant	An individual or organization that is one or more of the following within the PKI: WinnForum, a CA, a Subscriber, or a Relying Party.

PKCS #10	Public-Key Cryptography Standard #10, developed by RSA Security Inc., which defines a structure for a Certificate Signing Request.
PKCS #8	Public-Key Cryptography Standard #8, developed by RSA Security Inc., which defines a secure means for the transfer of private keys.
Processing Center	A secure facility created by an appropriate organization (e.g., Symantec) that houses, among other things, the cryptographic modules used for the issuance of Certificates.
Public Key Infrastructure (PKI)	The architecture, organization, techniques, practices, and procedures that collectively support the implementation and operation of a Certificate-based public key cryptographic system.
Relying Party	An individual or organization that acts in reliance on a certificate and/or a digital signature.
RSA (Algorithm)	A public key cryptographic system invented by Rivest, Shamir, and Adelman.
Secret Share	A portion of the activation data needed to operate the private key, held by individuals called “Shareholders.” Some threshold number of Secret Shares (n) out of the total number of Secret Shares (m) shall be required to operate the private key.
Secret Sharing	The practice of splitting a CA private key or the activation data to operate a CA private key in order to enforce multi-person control over CA private key operations.
Security Repository	Database of relevant security information accessible on-line.
Security Policy	The highest-level document describing security policies.
Sub domain	The portion of the PKI under control of an entity and all entities subordinate to it within the hierarchy.
Sub domain Participants	An individual or organization that is one or more of the following within the Subdomain: WinnForum, a Subscriber, or a Relying Party.
Subject	The holder of a private key corresponding to a public key. The term “Subject” can, in the case of a Device Certificate, refer to the Subscriber requesting the device certificate.
Subscriber	The entity who requests one or more Certificates (e.g., a manufacturer) to be installed in one or more devices under its control. The Subscriber is capable of using, and is authorized to use, the private key that corresponds to the public key listed in the Certificate (s).
Digital Certificate	An agreement used by a CA setting forth the terms and conditions under which an individual or organization acts as a Subscriber.
Subscriber Agreement	
Superior Entity	An entity above a certain entity within the PKI.
Trusted Person	An employee, contractor, or consultant of an entity within the PKI responsible for managing infrastructural

	trustworthiness of the entity, its products, its services, its facilities, and/or its practices.
Trusted Position	The positions within the MFGH entity that SHALL be held by a Trusted Person.
Trustworthy System	Computer hardware, software, and procedures that are reasonably secure from intrusion and misuse; provide a reasonable level of availability, reliability, and correct operation; are reasonably suited to performing their intended functions; and enforce the applicable security policy.
Validity Period	The period starting with the date and time a Certificate is issued (or on a later date and time certain if stated in the Certificate) and ending with the date and time on which the Certificate expires or is earlier revoked.

12 Abbreviations and Acronyms

This specification uses the following abbreviations:

CA	Certification Authority
CP	Certificate Policy
CPS	Certification Practice Statement
CRA	Certificate Requesting Account
CRL	Certificate Revocation List
CSR	Certificate Signing Request
DR	Demand Response
DRAS	Demand Response Automation Server
ECC	Elliptic Curve Cryptography
FIPS	Federal Information Processing Standards
id-at	X.500 attribute types. (OID value: 2.5.4)
id-ce	Object Identifier for Version 3 certificate extensions. (OID value: 2.5.29)
IETF	Internet Engineering Task Force
ISO	Independent System Operators
MFG	Manufacturer
OID	Object Identifier
WInnForum	Wireless Innovation Forum
um	
PA	Policy Authority
PKCS	Public-Key Cryptography Standard
PKI	Public Key Infrastructure
RFC	Request for comment
RSA	Rivest, Shamir, Adelman

Appendix I (Informative)

WinnForum wishes to thank everybody who participated directly or indirectly in the creation of this Certificate Policy.

Appendix II Document Change Notice History (Informative)

Table 11 shows the Document Change Notices that have been incorporated into this CP.

Table 11: Document Change Notice (DCN)

DCN	Author	Approval Date	Summary