

A Comparative Study of Eight Transfer Mechanisms with FM3TR

Jin Lian^{2,1,3}, Qi Tang^{1,3}, Li Zhou^{1,3}, Shan Wang^{1,3}, Haitao Zhao^{1,3}, Jun Xiong^{1,3}, Shengchun Huang^{1,3}, Jibo Wei^{1,3}

1 National University of Defense Technology, Changsha, Hunan, P.R. China

2 Hunan university, Changsha, P. R. China

3 Hunan Engineering Research Center of Software Radio, Changsha, P. R. China

Content

- ◆ Introduction
- ◆ Introduction of eight mechanisms
- ◆ FM3TR waveform
- ◆ Performance Measuring

Content

- ◆ Introduction
- ◆ Introduction of eight mechanisms
- ◆ FM3TR waveform
- ◆ Performance Measuring

Software defined Radio

- The future of the world is software-defined, e.g.,
 - Software defined radio (GNUradio, SORA, SCA, STRS, ALOE)
 - Cognitive radio
 - Software radar
 - Distributed computing
 - Embedded programmable System-on-Chip
 - Multiprocessor system
 - Cellphone

Transfer Mechanisms

- "Transfer Mechanisms should be viewed as a reusable, expandable set of services and functions that are commonly needed by many applications to function well in a networked environment".
- Classification
 - message oriented middleware (MOM): DDS, ZeroMQ
 - remote process all (RPC): ICE, RMI, gRPC, DDS-RPC and COM+
 - object request broker (ORB): ACE TAO, omniORB, e*ORB, ORBit
 - data distribute service(DDS): openDDS, OpenSlice DDS, RTI Connex DDS
 -

Content

- ◆ Introduction
- ◆ Introduction of eight mechanisms
- ◆ FM3TR waveform
- ◆ Performance Measuring

Introduction of eight mechanisms

- TAO
- omniORB
- e*ORB
- ORBit2
- ICE
- RPC over DDS
- RPCexpress
- TCP sockets

Content

- ◆ Introduction
- ◆ Introduction of eight mechanisms
- ◆ **FM3TR waveform**
- ◆ Performance Measuring

FM3TR waveform

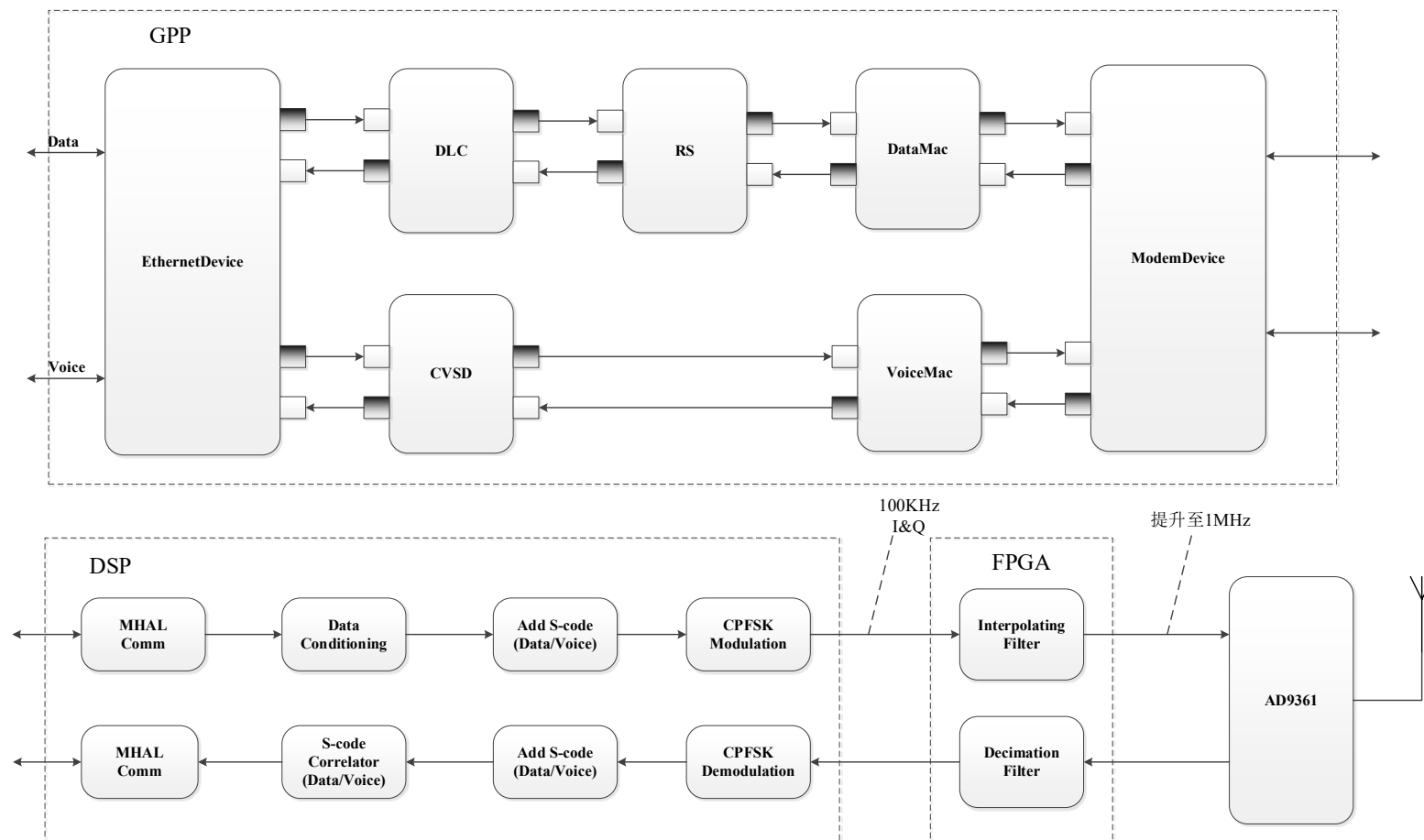

FM3TR waveform

- Devices & Components
 - EthernetDevice
 - DLC
 - RS
 - DataMac
 - CVSD
 - VoiceMac
 - ModemDevice

Content

- ◆ Introduction
- ◆ Introduction of eight mechanisms
- ◆ FM3TR waveform
- ◆ **Performance Measuring**

Experiment method

- For each transfer mechanism
 - Using the same implementation code of waveform
 - Creating the same interface of component
 - Implement the waveform
 - provide the same function, such as processing the voice data according to the requirement of FM3TR
 - Using the tools to record the latency, QPS, and memory size
 - Pre-processing the data of the experiment before analysis

Comparison metrics

- Different transfer mechanisms
 - Latency
 - throughput
 - Predictability
- Static footprint occupation
 - Skeleton & stub code size
 - Shared library size
- Dynamic memory occupation
 - Physical memory size of the process

Latency

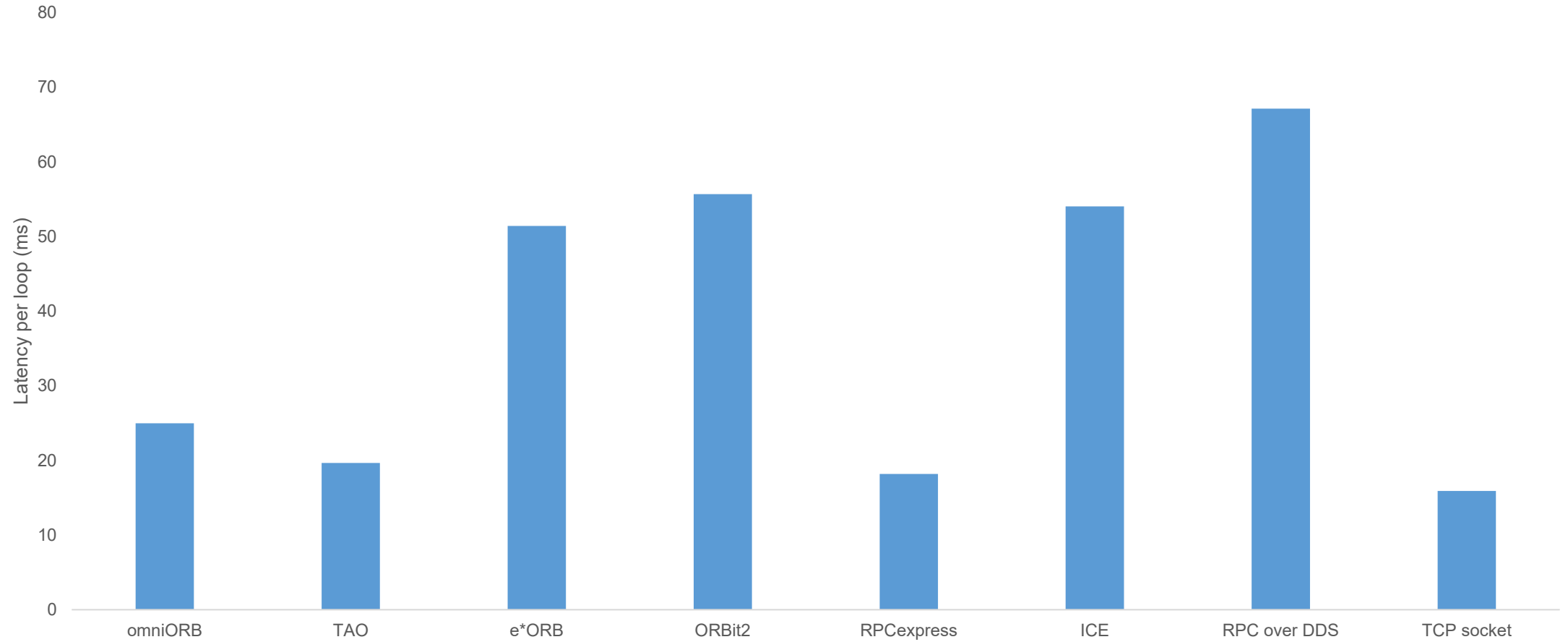

Throughput

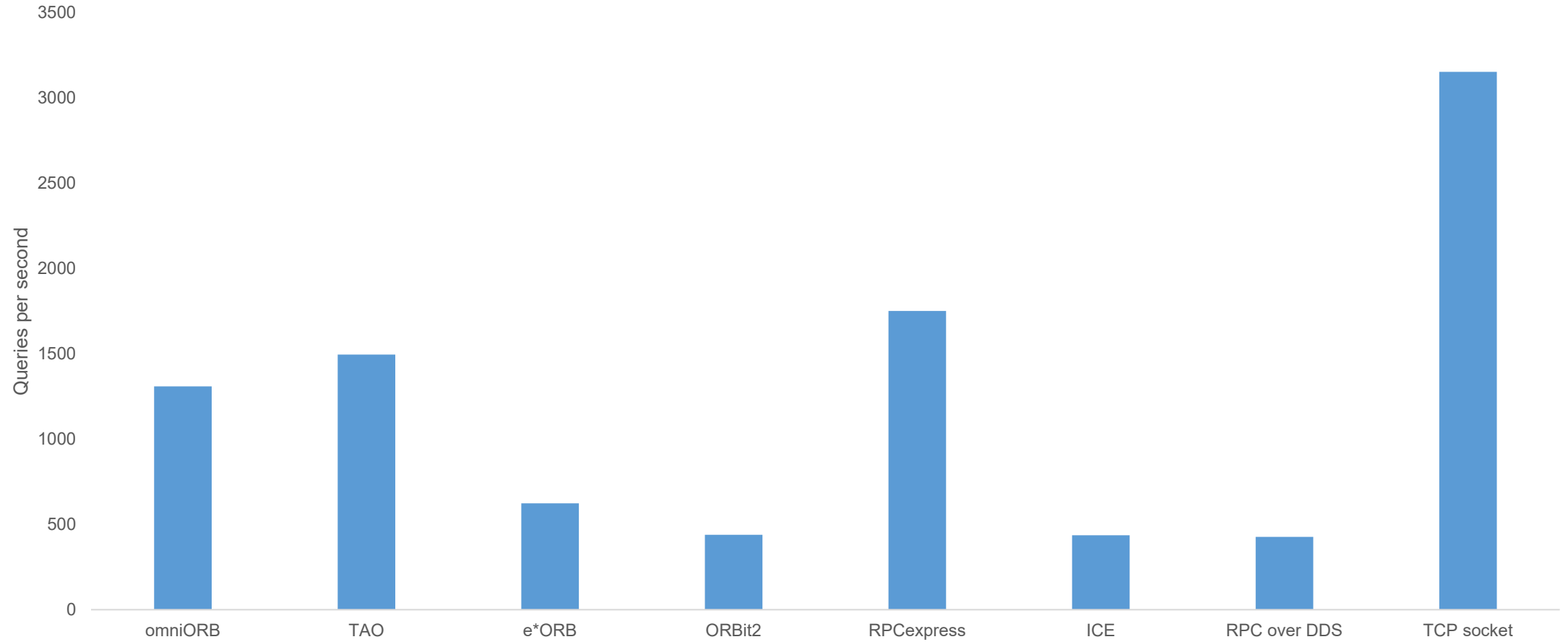

Predictability

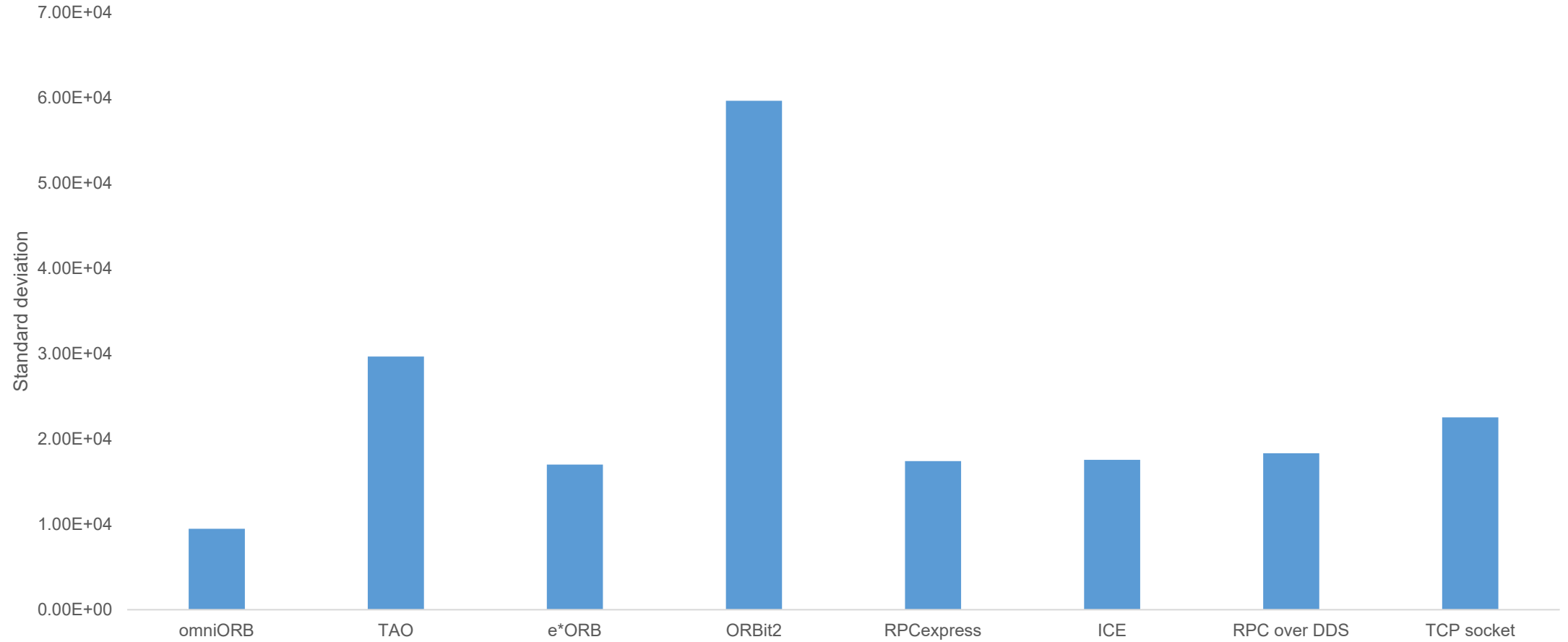

Static Memory Size

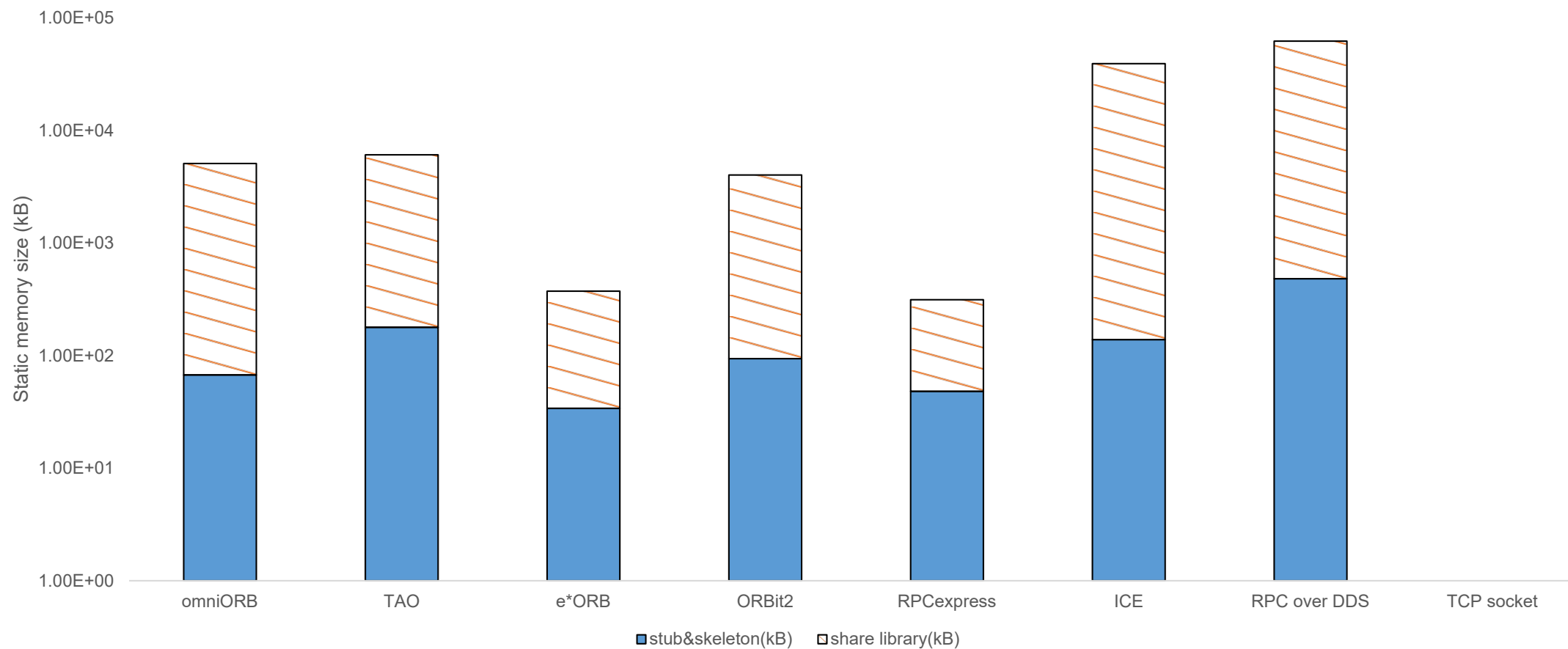

Dynamic Memory Size

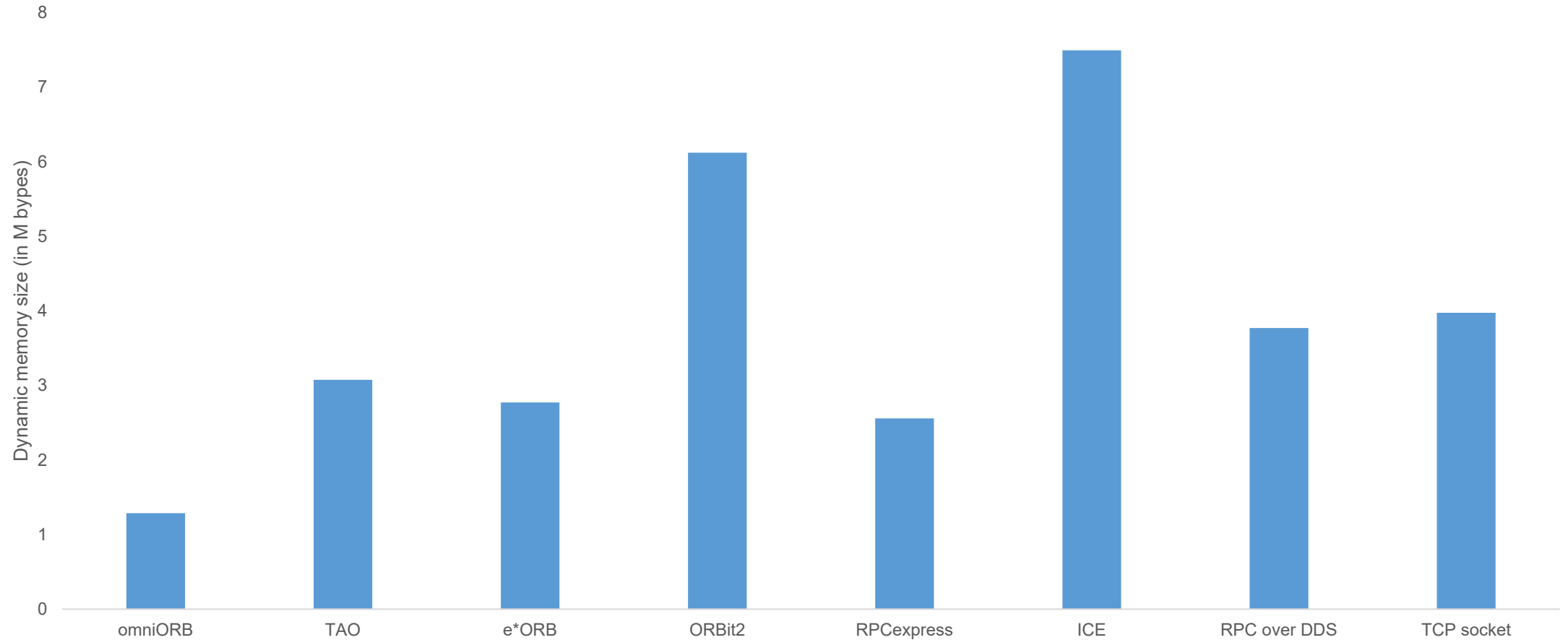

Thanks