

MULTI-SYSTEM OPTIMIZATION OF RF FRONT END WITH RELAXATION OF REQUIREMENTS

Toru Kitayabu (KDDI R&D Laboratories, Fujimino, Japan; to-kitayabu@kddilabs.jp);
Toshiyuki Maeyama (KDDI R&D Laboratories, Fujimino, Japan)

ABSTRACT

In order to offer customers a wide variety of services, mobile handsets have to support many communication standards: CDMA2000, WiFi, and Bluetooth. Multi-mode multi-band transceivers are very much in demand. The terminals have become increasingly complicated as they must support many communication standards. These standards normally require a separate RF front end because each system has different performance requirements. Software defined radio (SDR) technology has attracted attention as a means of realizing multi-system terminals with an associated reduction in terminal size.

This paper presents a design concept for a multi-system RF front end for SDR transceivers. Our proposal enables the sharing of RF components with relaxation of the performance requirements, assuming specific application of the SDR transceiver. We present some evaluation results for RF components' broadband properties and a specific example of multi-system RF front end design.

1. INTRODUCTION

There are many frequency bands and protocols for communications and broadcasting. The modern mobile phone works in such environments using a set of single function transceivers implemented on a single die or in a single package. Because these transceivers are dedicated to a specific band and protocol, the terminal become increasingly complicated as they support new bands or protocols. The SDR approach is expected to solve this problem. The traditional SDR approach of using a wideband analog to digital converter (ADC) close to the antenna is one way of realizing an SDR transceiver. However, this approach is not suitable for mobile applications due to the high power consumption of the wideband ADC.

Reconfigurable architecture is considered to be the key to realizing a battery driven SDR transceiver. A number of ideas have been proposed to make the RF front end reconfigurable [1], [2]. Regarding digital signal processing,

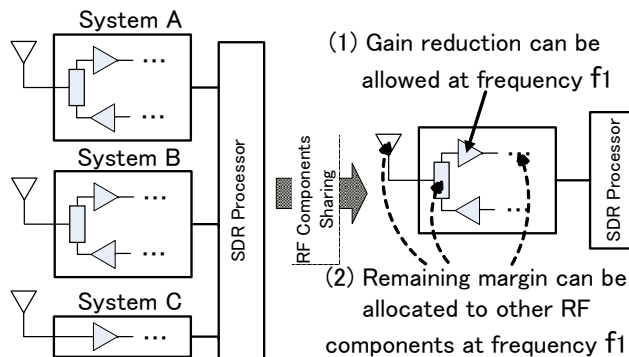

Figure 1. Concept of RF component sharing

as is well known, there are some DSP chips designed for mobile terminals. Furthermore, the results of an implementation of a CDMA2000 1xEV-DO [3] access terminal on a low-power-consumption DSP chip has been reported [4]. However, a reconfigurable RF device is not so easy to realize because the individual performance requirements are exacting.

In this paper we describe a design concept for a multi-system RF front end, which assumes specific application of the SDR transceiver and relaxation of the requirements for the RF front end and uses RF components across different systems.

2. DESIGN CONCEPT

We propose to manage and allocate the performance margins for several RF components through multi-system optimization for common use across different systems. The margins originate by limiting the use of the SDR transceiver to a specific application. Figure 1 shows our concept of sharing RF components.

2.1. Limitation of Application

By limiting the environment for the usage of an SDR transceiver, the performance requirement for the RF front end can be eased. The RF front end does not have to absolutely satisfy the exacting requirements. In a picocell or femtocell base station, the distance from a base station to a mobile terminal is up to several tens of meters. Thus, the

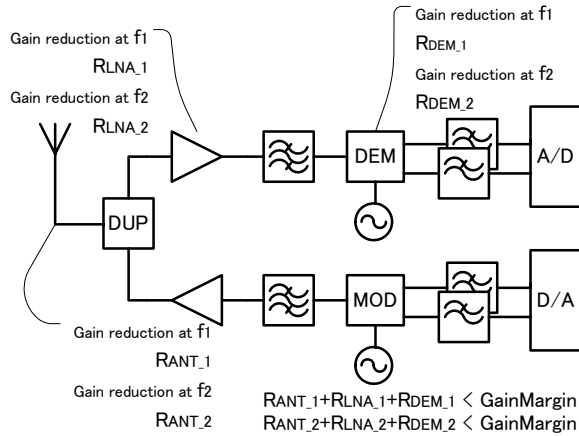

Figure 2. Example of distributing the performance margin

variation in free space loss is not large compared to that in a macro cell base station. In CDMA2000 1x/1xEV-DO systems, a typical maximum cell radius is roughly 3 km. If the systems are used in a picocell or femtocell base station, the shrinkage of the free space loss becomes a performance margin. The equation for free-space loss (FSL) in decibels is

$$FSL = 20 \log_{10}(d) + 20 \log_{10}(f) + 20 \log_{10}\left(\frac{4\pi}{c}\right) \quad (1)$$

where d is the distance from the transmitter to receiver (in meters), f is the signal frequency (in hertz), and c is the speed of light in a vacuum. If we assume an SDR transceiver is used in femtocell applications, the performance margin arising from the shrinkage of the free space loss is

$$20 \log_{10}\left(\frac{3000}{50}\right) = 35.56... \quad (2)$$

So, roughly a gain margin of 35 dB is distributable in every frequency band. This gain margin is used to ease the performance requirements for receiver sensitivity, receiver dynamic range, and transmission power.

Another example of application limitation is remote supervision of vending machines or industrial machines. If there is no demand for high-speed data transmission, the built-in communication modules have only to support just one minimum data transmission speed. In this case, for instance, the signal-to-noise ratio can be eased.

2.2. Distribution of Performance Margin

Figure 2 shows one example of distributing the performance margin. The performance margin is distributed to low noise amplifier (LNA), mixer, orthogonal modulator and orthogonal demodulator RF components. It is distributed so as to make each RF

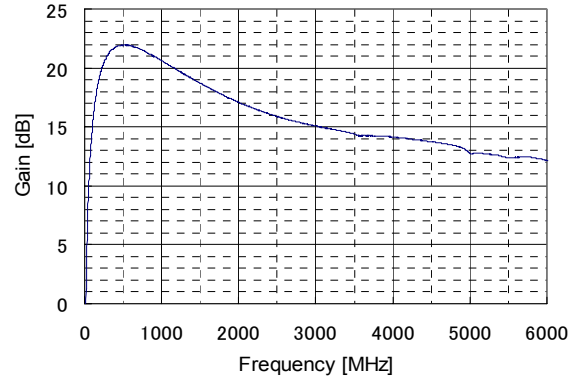

Figure 3. Gain characteristics of the power amplifier

component capable of being used across several frequency bands. There are several RF devices designed for wideband usage. Compared to the devices and peripheral circuits optimized for a specific frequency band, the devices and peripheral circuits designed for wideband usage undergo some performance degradation. But if this performance degradation is allowable, we can share the RF components across several frequency bands. The performance degradation is different in each frequency band, and each RF component has different frequency characteristics. Accordingly, we fit together the RF devices and adjust peripheral circuits so that the sum of performance degradation in each frequency band has a similar value and does not exceed the performance margin.

3. EVALUATION OF RF COMPONENTS

This chapter shows some results of the feasibility study on using a power amplifier and a variable gain amplifier (VGA) in wideband.

The evaluated power amplifier is Avago Technologies' MGA-425P8, which is designed for wireless application in the 2-10 GHz frequency range. The gain performances of this power amplifier with the referenced peripheral circuit are 16dB in 5.25 GHz and 20.5 dB in 2.6 GHz. To support digital terrestrial television broadcasting (470 – 770 MHz), we change the peripheral circuit from the reference circuit.

The evaluation results of the gain characteristics of the power amplifier are shown in figure 3. The gain of the power amplifier at 5.25 GHz is 12.7 dB and the gain at 2.6 GHz is 15.7 dB. The losses of the power amplifier gain stem from spreading the frequency band; i.e., 3.3 dB in 5.25 GHz and 4.8 dB in 2.6 GHz. If we allocate a 3.3 dB gain margin to the power amplifier at 5.25 GHz and a 4.8 dB gain margin at 2.6 GHz, we can use the power amplifier in two frequency band systems. In the example of the femtocell base station, the gain margin is about 35dB, so to

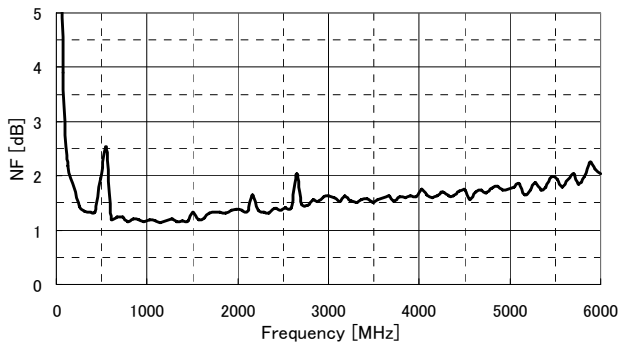

Figure 4. NF characteristics of the power amplifier

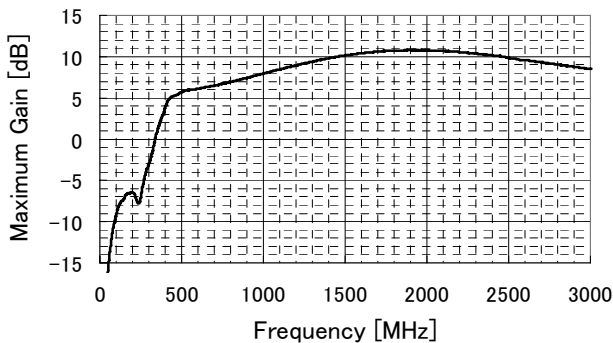

Figure 5. Gain characteristics of the VGA

allocate 3.3dB or 4.8dB gain margin is well within the capacity. In a similar manner, we can share the power amplifier among several frequency band systems by allocating a gain margin corresponding to each frequency band. The noise figure (NF) characteristics of the power amplifier are shown in figure 4. In some frequency bands, there is some degradation in the NF characteristics, but this degradation was a result of the influence of the experimentation environment. The noise figure is less than 2.0 dB from 400 MHz up to 5.25 GHz. These results mean that this power amplifier can be commonly used as an LNA in several frequency bands.

The evaluated VGA is NEC's uPC8204TK, which is designed for used in an automatic gain control (AGC) of PHS or wireless LAN transmitter. The design frequency range is from 0.8 GHz to 2.5 GHz. The maximum gain performances of this VGA with the referenced peripheral circuit are 14.5 dB in 1.9 GHz and 14.0 dB in 2.4 GHz. To use the VGA across a wider frequency range than the designed frequency range, the peripheral circuit was redesigned.

The evaluation results of the gain characteristics of the VGA are shown in figure 5. The gain of the VGA is greater than 6.9 dB from 800 MHz to 2.7 GHz, which is our target

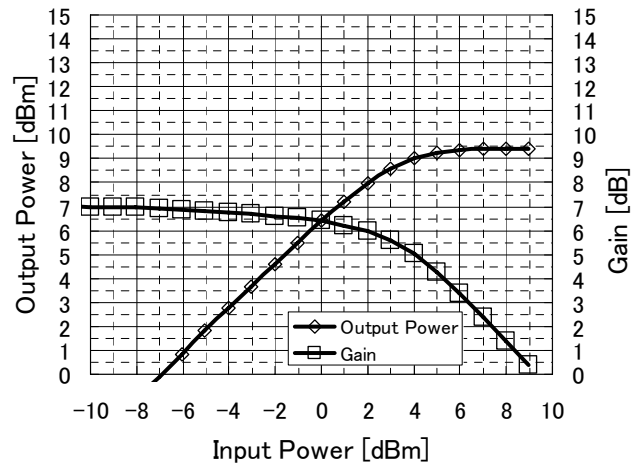

Figure 6. Input-output characteristics of the VGA under maximum gain at 870MHz

frequency band. The gain at 1.9 GHz is 10.8 dB and at 2.4 GHz is 10.2 dB. Thus, this VGA can be shared in a 1.9 GHz system and in a 2.4 GHz system by allocating a margin gain of 4 dB. Figure 6 shows the input-output characteristics of the VGA under maximum gain at 870 MHz. The 1 dB compression point (P1dB) at 870 MHz is +7.2 dB. Furthermore, the P1dB at 1434 MHz is +8.6 dB, the P1dB at 1930 MHz is +5.4 dB, the P1dB at 2450 MHz is +5.2 dB and the P1dB at 2585 MHz is +5.6 dB. By considering the linearity, the VGA is also utilizable in wideband by allocating the performance margin in each frequency band.

4 TRANSCEIVER DESIGN

Using the same concept of allocating the performance margin and sharing in each frequency band to the other RF components, a multi-system RF front end is designed. The target systems of our front end are:

- CDMA2000 1x/EV-DO, 800MHz/1.5GHz/2GHz
- Mobile WiMAX, 2.6GHz
- IEEE 802.11 b/g, 2.4GHz
- Bluetooth, 2.4 GHz
- Digital terrestrial TV, 470MHz

Figure 7 shows our RF front end design. It uses direct conversion architecture. Except for the BPFs, duplexer and local oscillator (LO), the other RF components are commonly used in every system. Basically, an existing discrete circuit is used to construct the RF front end. The base band filter is a fixed 20 MHz low pass filter (LPF) and the shortfall of the signal separation is compensated by digital LPF corresponding to the bandwidth of each system. The BPFs and the duplexers are connected to switches and they are switched according to the selected system. With respect to the LOs, as there are no LOs that support

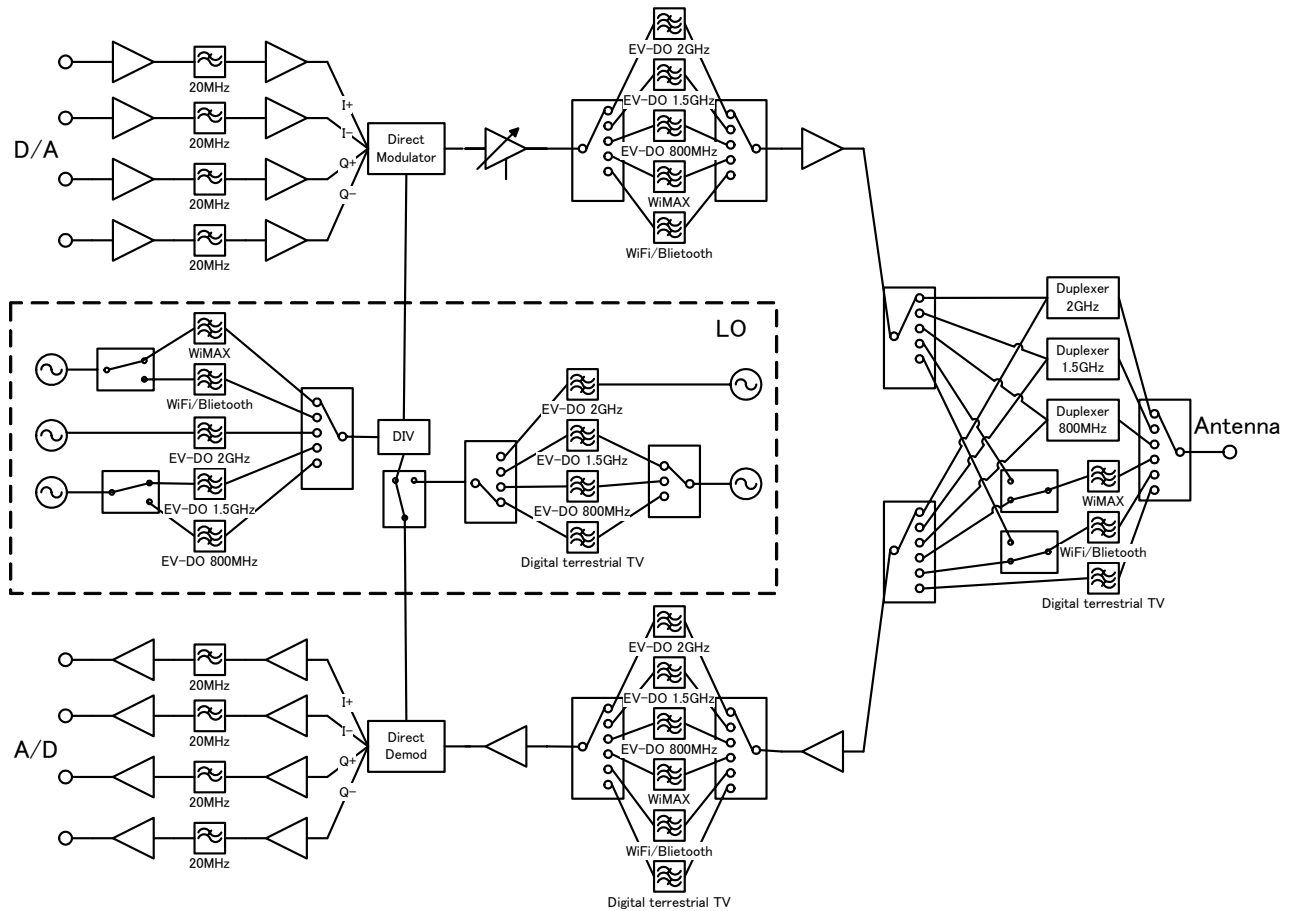

Figure 7. Multi-system RF front end design

frequencies from 470 MHz to 2.6 GHz, three LOs are provided for transmitter LOs and two LOs are provided for receiver LOs. In the TDD system, the LO's output is divided and is provided to the modulator and the demodulator. As a feasibility study, a level diagram of 2 GHz CDMA2000 1xEV-DO of our multi-system RF front end design shown in figure 7 has evaluated. Figure 8 is the result of the evaluation of the level diagram. In figure 7 some components are abbreviated, the proper components are as shown in figure 7. The total gain is 49.4 dB, the total NF is 5.8 dB and the receiver sensitivity is -110.9 dBm. We can say that each RF component is usable for the construction of a 2 GHz CDMA2000 1xEV-DO RF front end with the concept of being shared across every frequency band.

5. CONCLUSION

This paper has presented a design concept for a multi-system RF front end for SDR transceivers. Our proposal is to share RF components in association with a relaxation of the performance requirements, assuming specific application of the SDR transceiver. Some concrete results

of the performance evaluation of the power amplifier and a VGA are presented. Although, there is some performance degradation due to the use in wider frequency bands, these effects are compensated by the performance margin stem from assuming specific application such as femtocell base station. With regarding to the performance of each RF components using across several frequency bands, a level diagram of a 2 GHz CDMA2000 1xEV-DO RF front end with our concept are evaluated. The result of the level diagram evaluation shows the RF front end is usable from the viewpoint of receiver sensitivity. A multi-system RF front end design based on RF component sharing has also been presented.

6. REFERENCES

- [1] Panfilov O., Jae J., Turgeon T., Hickling R., "Coming Revolution in Communication-True Software Radio Systems," CriMiCo'2005 Ukraine, pp. 12-15, Sept. 2005.
- [2] Erik L. Org, Russell Cyr, Geoff Dawe, John Kilpatrick, "Software Defined Radio Architectures for Mobile Communication Applications," SDR'06 Tech Conf.
- [3] 3GPP2 C.S0033 Version 2.0, "Recommended Minimum Performance Standards for cdma2000 High Rate

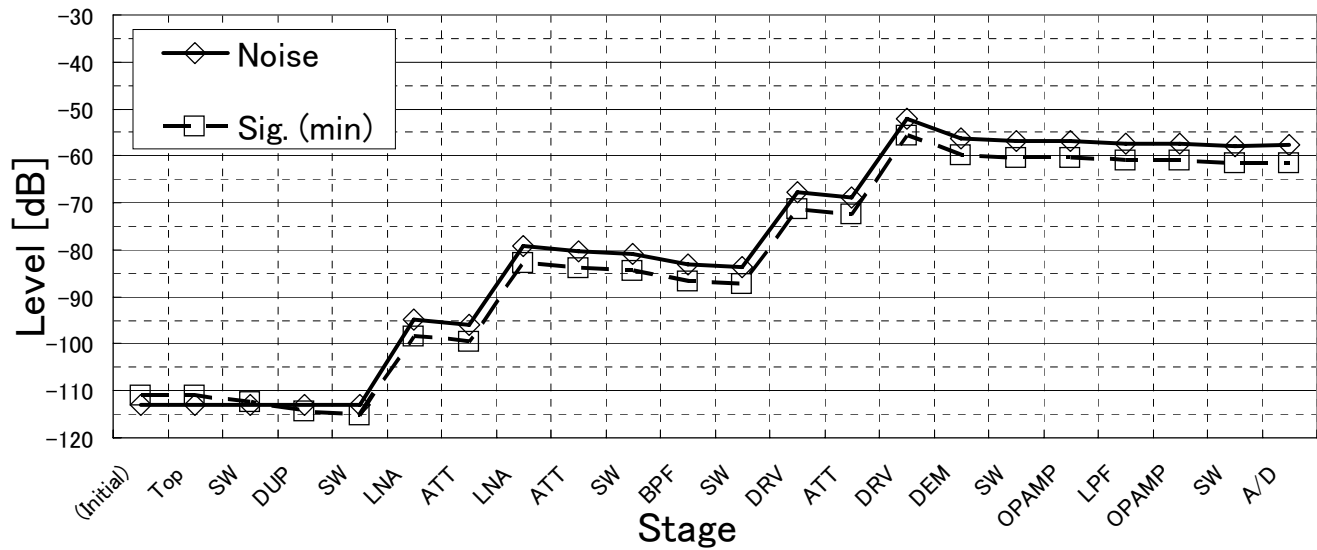

Figure 8. Level diagram of 2GHz CDMA2000 1xEV-DO of the multi-system RF front end design

Packet Data Access Terminal,” Jan. 2004,
http://www.3gpp2.org/Public_html/specs/C.S0033-0_v2.0_121703.pdf

- [4] S. Watanabe, Y. Kunisawa, D. Kamisaka, T. Inoue, Y. Takeuchi, “A Software Radio Implementation of CDMA2000 1xEV-DO on a Single DSP Chip Designed for Mobile Handset Terminal,” IEEE Vehicular Technology Conference 2006 Fall (VTC2006Fall), Sep. 2006, Montreal, CanadaSDR’06 Tech Conf.
- [5] ARIB STD-B31, “Transmission System for Digital Terrestrial Television Broadcasting,” Nov. 2005 (in Japanese) <http://www.dibeg.org/aribstd/ARIBSTD.htm>