

DESIGN AND IMPLEMENTATION OF AN ALGORITHM FOR MODULATION IDENTIFICATION OF ANALOG AND DIGITAL SIGNALS

John Yong Jia Chen (Department of Electrical Engineering, San José State University, San José, California, USA, johnchen_calpoly@yahoo.com);
 Robert Morelos-Zaragoza (Department of Electrical Engineering, San José State University, San José, California, USA, rmorelos@helios.sjsu.edu)

ABSTRACT

In the application of a software radio system, the design of a dynamic transceiver needs to take into account adaptation to various types of incoming signals in an unknown environment. An algorithm is developed as part of this design to appropriately identify the signal's modulation type. The key feature of the proposed algorithm is in the use of a wavelet transform to explore different features of the received signal such as power spectral density, variance, and the amplitude and peaks of the wavelet transform of the signal. As a result, it is possible to successfully classify an incoming signal to have an analog modulation type of AM or FM, or a digital modulation type such as M-PSK, M-FSK or M-QAM. With knowledge of the modulation type of the incoming signal, the transceiver is able to choose the appropriate demodulation software algorithm in order to retrieve the transmitted information. To improve upon the performance of the algorithms at relatively high signal-to-noise ratio (SNR) values, the signal samples are further processed using a robust identification technique based on the a-posteriori probability density function.

1. INTRODUCTION

A software defined radio (SDR) system has gained its popularity over the years because of its flexible architecture and potential for great utilities in the communication world. One of the flexibilities that a SDR can offer is the ability to receive and decode signal with different modulation schemes. In the SDR architecture, the portion that allows the system to have this flexibility is the element that can identify the modulation scheme of a received signal and use this information to choose the appropriate demodulation algorithm to decode the transmitted messages. The main objective for this paper is to develop an algorithm to identify analog and digital signals with the modulation types such as the amplitude modulation (AM), frequency modulation (FM), phase shift keying (M-PSK), and frequency shift keying (M-FSK).

The classification method for quadrature amplitude modulation (QAM) is briefly explored as well.

2. CLASSIFICATION ARCHITECTURE

In order to successfully develop a robust algorithm for identifying analog and digital modulation types, it is necessary to understand the different types of modulation schemes. Some common analog modulations are Amplitude Modulation (AM), and Frequency Modulation (FM). Some common digital modulations are Phase Shift Keying (PSK), Frequency Shift Keying (FSK) and Quadrature Amplitude Modulation (QAM).

Once there is a good understanding of each type of analog and digital modulation schemes, the focus will be placed upon the classification method that looks into the frequency contents of the modulated signal and the method that utilizes the wavelet transform.

An algorithm for modulation identification of analog and digital signals is developed. The algorithm should be capable to identify both analog and digital signals in an unknown environment with no a-priori knowledge of the modulation scheme of the incoming signal. In the design of this algorithm, it is assumed that perfect synchronization has been established and that no interference is present. However, the effectiveness of the algorithm will be explored in various noise conditions. Figure 1 depicts the block diagram for the modulation identification algorithm.

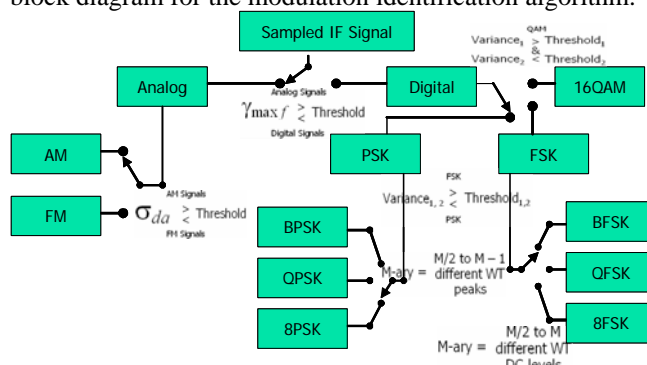

Figure 1 – Classification Block Diagram

The received intermediate frequency signal is first sample. The algorithm will decide whether the signal is an analog signal or a digital signal. If it is determined as an analog signal, the algorithm will further classify it as either an AM signal or a FM signal. On the other hand, if the algorithm classifies the signal as a digital signal, then the algorithm will determine if that signal has a PSK, a FSK or a QAM modulation. Upon successful classification of a PSK, FSK or QAM modulated signal, the algorithm continues to process the signal to determine its M value as in M-PSK, M-FSK or M-QAM. In this paper, M = [2, 4, 8] for PSK and FSK modulations, and M = [16, 32, 64] for QAM.

2.1. Analog/Digital Separation Block

To successfully classify the sampled intermediate frequency signal to be an analog signal or digital signal, the algorithm explores the power spectral density (PSD) of the instantaneous frequency of the sampled signal. Based on the characterization of analog signals and digital signals, threshold levels are set within a signal to noise ratio (SNR) range from -6dB to 30dB. If the maximum value measured in dB of the PSD is greater than the threshold, then the signal is classified as an analog signal. On the other hand, if it is less than the threshold, then the signal is considered as a digital signal.

In order to find the maximum value of the PSD of the instantaneous frequency of the sampled signal, the equation is as follows:

$$\gamma_{\max f} = 20\log_{10}(\max|DFT(f_n(i))|)$$

The instantaneous frequency of the sampled signal will need to be calculated first. The discrete Fourier transform (DFT) is then applied to the result and after that the maximum value is determined. Taking $20\log_{10}$ of the answer will transform the answer in terms of decibel (dB). The algorithm will compare this answer to the preset threshold value and determine the sampled signal is analog or digital. The following figure summarizes the classification scheme for this block.

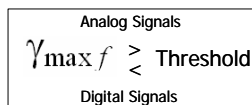

Figure 2 – Analog/Digital Classification Scheme

2.2. Analog Modulation Identification Block

Once the sampled signal is classified as an analog signal, the algorithm will go down the analog modulation identification path where it will determine if the sampled signal is either amplitude modulated (AM) signal or frequency modulated (FM) signal. To accomplish this task,

the algorithm looks at the standard deviation of the instantaneous amplitude of the non-weak segments of the sampled signal. Based on the characterization of the AM and FM signals, threshold values are set within a signal to noise ratio (SNR) range from -6dB to 30dB. If the standard deviation is greater than the threshold, then the signal is considered as an AM signal. Otherwise, the sampled signal will be classified as FM signal. The equation for the standard deviation of the instantaneous amplitude of the non-weak segments of the sampled signal is as follows:

$$\sigma_{da} = \sqrt{\left[\frac{1}{N_s} \sum_{A_n(i) > a_t}^{N_s} A_n^2(i) \right] - \left[\frac{1}{N_s} \sum_{A_n(i) > a_t}^{N_s} A_n(i) \right]^2}$$

where A_n is the instantaneous amplitude and N_s is the number of non-weak signal segment samples.

Once this step is complete, a threshold is set to isolate the non-weak signal segments. After that, a MATLAB script code is used to generate the standard deviation that is needed for the classification procedure.

After the standard deviation is generated, the answer is then compared to the thresholds set for classifying AM and FM signals. Again, if the standard deviation is greater than the threshold, then the signal is considered as an AM signal. Otherwise, if it is less than the threshold then the sampled signal will be classified as FM signal. The following figure summarizes the classification scheme for this block.

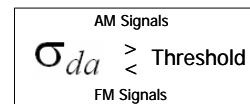

Figure 3 – AM/FM Classification Scheme

2.3. Digital Modulation Identification Block

On the other hand, if the original sampled intermediate frequency signal is determined as a digitally modulated signal, the digital modulation classification techniques will be employed. In this identification block, the algorithm is capable to classify the signal as either a PSK or FSK signal. Classification of quadrature amplitude modulation (QAM) will be discussed in later sections of this paper.

The following figure represents the classification algorithm used to process the input digital signal and determine whether it is PSK or FSK modulated.



Figure 4 – PSK/FSK Classification Block Diagram

The input digital signal is processed by the wavelet transform block. The magnitude of the result is taken. After that, the processed result is down sampled to reduce the processing intensity and requirements. Median filtering is applied to filter out the peaks. Variance of the end result is measured and used for comparison purposes later on.

The idea for applying wavelet transform to the input digital signal is that it brings out distinct features in the PSK and FSK signal that allow the algorithm to distinguish between the two modulation types. The magnitude of the wavelet transform of the PSK signal will show that there is one DC level and many levels of peaks depending on the M-PSK. On the other hand, the wavelet transform magnitude of the FSK signal will have several levels of DC levels and peaks. The following figure depicts this idea in graphical form.

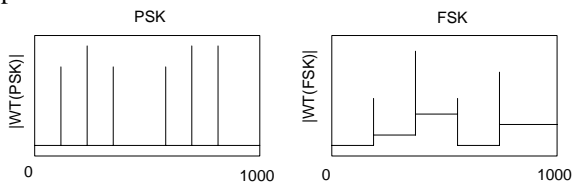

Figure 5 – Wavelet Transform Magnitude Examples

From the figure, it can be seen that one distinguishing factor between the PSK and the FSK is the number of DC levels each has. In order to just focus on the DC levels, median filtering is applied to get rid of the peaks. Once only the DC levels are shown, it can be shown that the variance for the wavelet transform magnitude of the PSK signal is small as compared to a bigger variance for the FSK case because of multiple DC levels. Using the variance as just described, the algorithm can identify if the input digital signal is a PSK signal or a FSK signal.

The threshold values set for classifying PSK and FSK signals using the variance parameter is generated based on the characterization of the variance of the wavelet transform magnitude of the PSK and FSK signal. Again, these values are set within a signal to noise ratio (SNR) range from -6dB to 30dB. The following figure summarizes the classification scheme for this block.

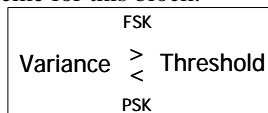

Figure 6 – FSK/PSK Classification Scheme

2.4. M-PSK Classification Block

When the signal is classified as a PSK signal, the algorithm will further process the data and tries to determine the M

value in M-PSK. Exploring the features generated by using the wavelet transform, the wavelet transform magnitude of the PSK case will show a peak where there is a phase change in the modulated signal. Depending on the M-PSK and the different values of the phase change, the peak values generated are different. This fact can be exploited to determine the number of different value phase change to find out the value for M. There is no need to know the exact value of these peaks, but the number of different peak values need to be found to correlate to the value for M. Also, when there is oversampling of the modulated signal, the wavelet transform magnitude from $+\alpha$ and $-\alpha$ phase changes will be identical. Therefore, there will only be $M/2$ different peaks for M-PSK. To sum up, M is equal to the number of $M/2$ to $M-1$ different wavelet transform peaks.

The algorithm that is used to determine the number of different wavelet transform magnitude peaks is described in the following figure.

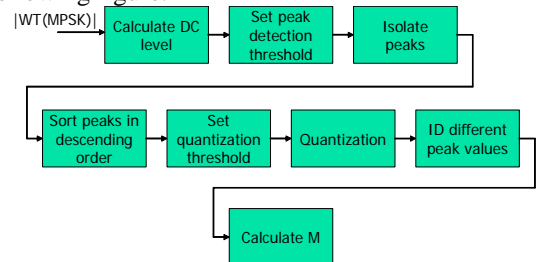

Figure 7 – M-PSK Classification Algorithm Block Diagram

The algorithm will take in the wavelet transform magnitude of the M-PSK signal and process it. The first task is to isolate all the peaks in the signal sample. This is achieved by calculating the DC level and uses that information as a baseline value. Next detection threshold values are set based on the calculated baseline DC level. Values of the signal sample are compared to the threshold and therefore isolated only the peaks. The second task is to find the number of different peaks. These isolated peaks will be rearranged and sorted in descending order for the algorithm to sweep through from the beginning of the sample to the end of the sample for the purpose of quantization. The accuracy of determining the number of different peak values is sensitive to the quantization threshold values. Many realizations of the algorithm are performed to identify the optimum threshold values to be implemented in the algorithm. Finally, after the number of different peak values is identified, the algorithm will correlate that result to calculate M.

The following figure is an example of the wavelet transform magnitude for BPSK modulated signals using real data. It can be seen that there is only one WT peak value.

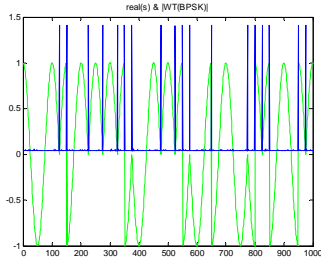

Figure 8 – Example of BPSK and its WT Magnitude

The following figure summarizes the classification scheme for this block.

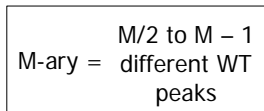

Figure 9 – M-PSK Classification Scheme

2.5. M-FSK Classification Block

When the signal is classified as a FSK signal, the algorithm will further process the data and tries to determine the M value in the M-FSK. Exploring the features generated by using the wavelet transform, the M value can be found. The wavelet transform magnitude of the FSK case will resemble a multi-step function with the number of DC levels equals to the number of modulation frequencies. Depending on the M value of the modulated M-FSK, there will be M/2 to M number of different wavelet transform magnitude DC levels.

The algorithm that is used to determine the number of different wavelet transform magnitude DC levels is described in the following figure.

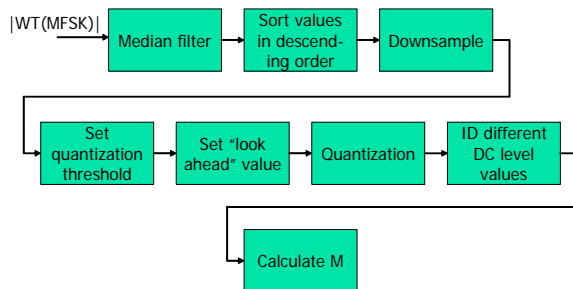

Figure 10 – M-FSK Classification Algorithm Block Diagram

The algorithm will take in the wavelet transform magnitude of the M-FSK signal and process it. The first task is to apply median filtering to get rid of all the unwanted peaks, especially in the case of non-continuous phased FSK signal where peaks will occur in the wavelet transform magnitude samples. The idea is to isolate and focus on the DC level values, which is used as a distinguishing feature to determine the value M. After

applying the median filter, the values are sorted in descending order. The resulting data is then downsampled to reduce computational requirements. The algorithm will try to identify the different DC levels by first setting the quantization thresholds and the “look ahead” values. The algorithm will sweep through from the beginning of the data sample to the end and use the threshold and “look ahead” values to quantize the data sample to discrete values. These discrete values are supposedly the different DC levels in the wavelet transform magnitude of the M-FSK. After the number of different DC levels is found, the algorithm will correlate this result to determine the M value in the M-FSK.

Figure 11 is an example of the wavelet transform magnitude for BFSK modulated signals using real data.

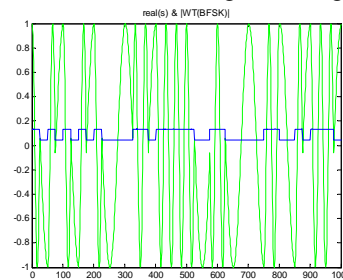

Figure 11 – Example of BFSK and its WT Magnitude

The following figure summarizes the classification scheme for this block.

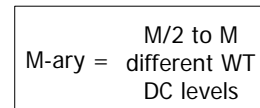

Figure 12 – MFSK Classification Scheme

2.6. QAM Classification Block

Assuming the intermediate frequency signal is correctly determined as a digital signal; an algorithm is developed to classify QAM signals in addition to PSK and FSK signals. This algorithm also explores the usage of the wavelet transform to extract special features from each of the modulation types, namely PSK, FSK and QAM. Similar to the algorithm developed to only classify PSK and FSK signals, this algorithm follows similar data processing procedures. The difference for this algorithm is that additionally it also normalizes the original input intermediate frequency signal.

Then, the wavelet transform magnitude of the normalized input signal is generated. For QAM signals, the wavelet transform magnitude of the original signal will have multiple DC levels as well as different peak values. It looks similar to the wavelet transform magnitude for FSK signals. However, the wavelet transform magnitude of the normalized input signal will only have one DC level and

multiple peak values, much like the ones for PSK signals. Based on this observation, a classification scheme is apparent. An algorithm can then be developed to distinguish between PSK, FSK, and QAM signals. The following figure depicts this idea in graphical form.

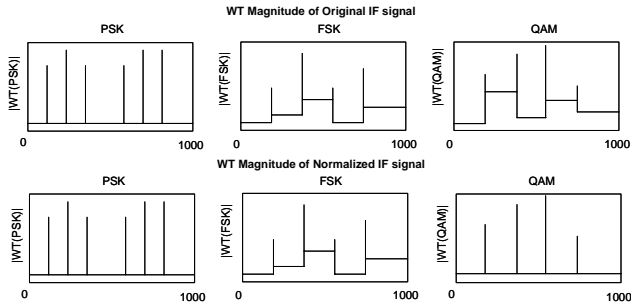

Figure 13 – Wavelet Transform Magnitude Examples for Original and Normalized Intermediate Frequency Signals

From the figure above, it can be seen that the algorithm can use the variance of the wavelet transform magnitude of the original and normalized intermediate frequency signals to classify between PSK, FSK, and QAM modulated signals. The variance will be measured after the peaks are filtered out as much as possible by applying median filtering. The following figure summarizes the classification scheme for this block.

	PSK	FSK	QAM
$\text{VAR}(\text{WT}(\text{original}))$	< Threshold	> Threshold	> Threshold
$\text{VAR}(\text{WT}(\text{normalized}))$	< Threshold	> Threshold	< Threshold

Figure 14 – PSK/FSK/QAM Classification Scheme

3. SIMULATION RESULTS

The simulated input signals are generated in MATLAB for the AM, FM, BPSK, QPSK, 8PSK, BFSK, QFSK, 8FSK and 16QAM modulations. For the analog signals, an arbitrary waveform is selected. This waveform is then modulated using AM or FM modulation techniques. Following that, all white Gaussian noise (AWGN) is added to the waveform to simulate various noise conditions with SNR range from -6dB to 30dB. For the digital signal, randomly generated message numbers are used in accordance to the selected M value. That set of message number is converted to analog waveform using square waves and then modulated using the PSK, FSK or QAM techniques. The modulated waveform is up converted to intermediate frequency signals and injected with AWGN range from -6dB to 30dB.

The algorithm can successfully classify AM and FM signals as shown by simulation results in Figure 15.

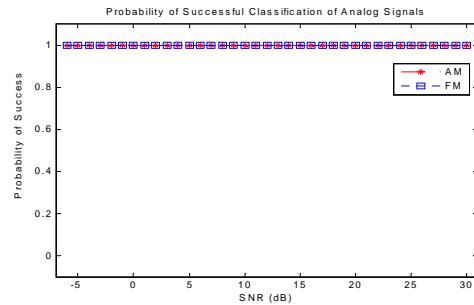

Figure 15 – Probability of Successful Classification of Analog Signals

For the M-PSK modulation classification, the algorithm shows its robustness in its accuracy for signals with SNR above -3dB. This can be seen in simulation results in Figure 16.

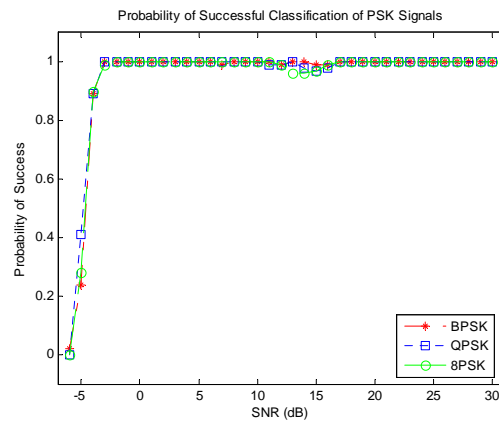

Figure 16 – Probability of Successful Classification of PSK Signals Using PSK/FSK/QAM Algorithm

As depicted in Figure 17, classifying M-FSK signal accurately with this algorithm requires a higher SNR value.

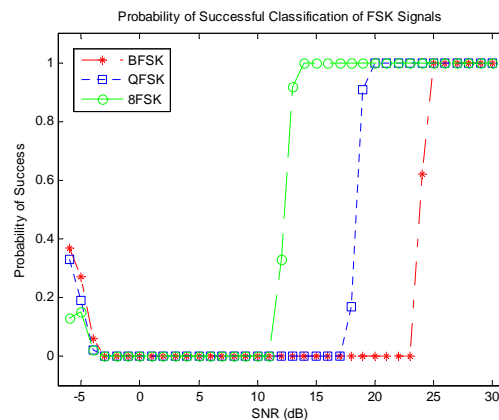

Figure 17 – Probability of Successful Classification of FSK Signals Using PSK/FSK/QAM Algorithm

The algorithm performs better in the M-QAM classification scenarios, Figure 18, as compare to the M-FSK scenarios.

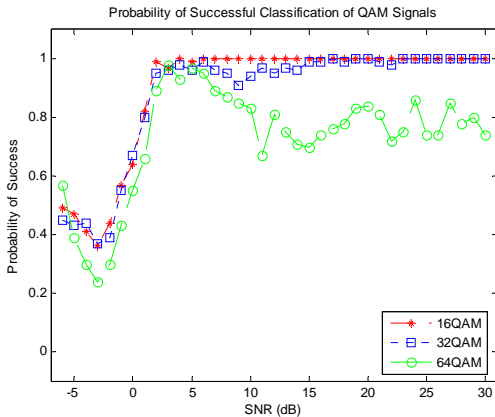

Figure 18 – Probability of Successful Classification of QAM Signals Using PSK/FSK/QAM Algorithm

In order to optimize the performance of the algorithm when classifying modulations such as M-PSK, M-FSK, and M-QAM, appropriate threshold values are selected and implemented within the algorithm. These values maximize the probability of successful classification for the digital modulations explored in this paper. As SNR increases, the distinguishing features used in the algorithm to classify the modulation type become more apparent, therefore increasing the algorithm’s accuracy. Conversely, as SNR decreases, the signal and its distinguishing features are drown in noise and make classification more difficult.

4. CONCLUSION

In this paper, an algorithm is developed using the MATLAB language to identify or classify the modulation type of an unknown signal. This unknown signal can be either digital or analog modulated. The modulation types being considered are AM, FM, BPSK, QPSK, 8PSK, BFSK, QFSK, and 8FSK. The modulation types of 16QAM, 32QAM, and 64QAM are evaluated as well for the QAM classification scheme case. The algorithm is evaluated in the SNR range from -6dB to 30dB for robustness and accuracy. The algorithm developed under this project explores the characteristics in a signal such as power spectral density, variance, and wavelet transform magnitude. The challenges that have surfaced include setting the optimal threshold values in many instances to produce the best results and performance of the algorithm under various noise conditions and modulation types. The performance and accuracy of the algorithm is best when classifying between digital and analog signals. It is also near perfect when distinguishing between AM and FM signals. In terms of classifying PSK, and FSK signals, the performance is optimized because of

the constraints of setting the optimal threshold levels for the algorithm. Similarly, when trying to classify the various M-PSK and M-FSK signals, the task of finding the optimal threshold levels is also challenging. As the SNR decreases, the accuracy will be reduce as well because the distinguishing features generated by the wavelet transform will be drown by noise. It is therefore increasingly difficult for the algorithm to identify the distinguishing features for accurate classification.

This paper also explores the classification scheme for QAM signals. The results seem to give relatively good performance when successfully classifying QAM signals. However, perhaps there is a little sacrifice made in the performance for the FSK signal classification that could yield better results.

Building on the foundation and algorithm that have been developed under this paper, possible future work can include optimizing the algorithm for faster speed and better accuracy and performance. The capability of the algorithm for additional modulation types can be developed as well as using different classification schemes to identify the same modulation types as described in this paper. Ultimately, the algorithm can be further developed to implement into hardware devices.

As the technology for the software defined radio (SDR) grows more mature, there will be increasing demand for better software that can add more capabilities to the existing SDR systems. Having the ability to detect the modulation types of a received signal allows the flexibility for the SDR to adapt quickly to changing radio protocols. This paper has achieved its objective to develop an algorithm that can classify different modulation types and has the potential to ultimately be implemented in hardware devices. To that end, the algorithm allows the SDR to classify the modulation type of a received signal and use that information to select the appropriate demodulation algorithm to decode the transmitted information.

10. REFERENCES

- [1] K. E. Nolan , L. Doyle, D. O’Mahony & P. Mackenzie, “Modulation Scheme Recognition Techniques for Software Radio on a General Purpose Processor Platform”, in *Proceedings of the First Joint IEI/IEEE Symposium on Telecommunications Systems Research*, Dublin, November 27th, 2001
- [2] K. C. Ho, W. Prokopiw and Y. T. Chan, “Modulation Identification of Digital Signals by the Wavelet Transform”, in *IEE Proceedings - Radar, Sonar and Navigation*, Vol. 147, Issue 4, page(s): 169-176, August 2000
- [3] L. Hong, K.C. Ho, “Identification of digital modulation types using the wavelet transform”, in *Proc. IEEE Military Commun. Conf. MILCOM '99*, page(s): 427-431, New Jersey, Oct. 1999