

BENEFITS OF SUPERCONDUCTOR MICROELECTRONICS FOR COMMERCIAL WIRELESS BASE STATIONS

Jack Rosa (HYPRES, Inc., Elmsford, NY, USA, jrosa@hypres.com)

HYPRES Superconducting MicroElectronics (SME) technology provides, for the first time, the ability to operate and process the RF domain in the digital world.

HYPRES Superconducting MicroElectronics (SME) Technology provides unparalleled performance improvements in the digital domain allowing, for the first time, the direct digital conversion of RF signals while enabling the use of advanced ultra-high speed digital signal processing techniques. SME makes it possible to take the receive (or transmit) signal directly at the output of the base station antenna and directly convert (ADC) it into the digital format for further processing. The ultra low noise, high speed and sensitivity of the HYPRES Digital-RF allows spectrally pure frequency conversion and signal demodulation. Our technology affords many, hereto for unobtainable, benefits that can significantly improve the performance and cost of commercial wireless networks and base stations.

Performance degradations caused by thermal and spurious noise generated by analog frequency converters are eliminated. The Digital-RF front end contributes virtually no noise or signal distortion to the incoming signal. This low noise feature and the significantly enhanced sensitivity of Digital-RF translates to expanded regions for higher data rates and soft handoff, and substantially greater base station range and separation. These unique features result in enhanced network optimization and increased capacity (number of users and data rates/cell).

Digital processing in the RF domain enables (for the first time) use of optimum digital correlation techniques to increase $S/(N+I)$ performance by providing near real-time interference and thermal noise suppression. This enables an increase in bandwidth utilization & user data rates while further reducing antenna & HPA size. The HYPRES transceiver is capable of simultaneous reception and decoding of multiple signals over a ultra-broad frequency band. HYPRES hardware is not specific to any

analog/digital modulation or multiple access scheme.

High speed digital processing directly at the transmit frequencies enables the direct linearization of the multi-GHz waveform at the HPA input by using broadband RF pre-distortion to dynamically correct all distortions in near real time. This enables multi-carrier operation via a single HPA while simultaneously optimizing in-band performance and minimizing out-of-band spurious effects far beyond what current (or forecasted) technologies can achieve. This also represents a significant reduction in initial and operating cost, due to much higher HPA efficiencies, reducing HPA and related cost by 50% to 75%. Unique features in antenna optimization provide the ability to balance the forward (transmit) and reverse (receive) links without an increase in antenna size.

HYPRES technology offers many benefits to users, operators and suppliers of wireless networks and regulatory agencies (FCC, etc.):

Massively Reduced Network Capital Expenditures

Much Fewer Base Stations - HYPRES technology significantly expands base station range coverage and capacity, enabling a dramatic reduction of the total number of base-station sites required, thereby reducing total network capitalization by an order of magnitude. SME technology enables wideband 3G performance with 2G base-station range.

Lower Capitalization per Base Station - One digital radio performs the tasks of many conventional protocol-and frequency-specific base station radios. For example, the critical communication equipment is reduced by about 90% (to about 10%) of a traditional GSM base station. A single universal platform can be configured dynamically and/or periodically (in the factory or in the field) to suit many different services, independent of communication bandwidth or standard. This versatility significantly reduces the cost of base stations and the infrastructure provider's spares inventory needed to accommodate multiple protocols.

Postponement (“one size fits all” – “air interface immune”) - There are many benefits. For example: early in the life cycle, a dramatic reduction in inventory breadth and cost for the infrastructure supplier; and later in the life cycle, the unique flexibility to change the “personality” of the base station without “fork-lifting out” the equipment – truly future proof.

Reduced Operating Expenses

Fewer base stations translates into fewer (costly) connected landlines and less power consumed. Less power consumed per base station is a significant further reduction. High reliability and nearly maintenance free operation further reduces operating cost. Resistance to surges and lightning strike effects means far less repair cost.

Enhanced Revenues and Margins

Because of the higher receiver sensitivity, resolution, and processing speed enabled by the HYPRES technology, more traffic for a given bandwidth allocation is possible, allowing additional users and/or services to be added at will, without upgrading the infrastructure. Our superior interference rejection results in higher call quality, few dropped calls, and, in turn, increased customer usage.

Boost Spectral Efficiency

Current state-of-the-art wireless systems only provide 0.5 to 0.8 bits/sec/Hz, in terms of their ability to exploit (i.e., generate revenue from) an allocated bandwidth. In contrast, the HYPRES approach can provide more than 8 bits/sec/Hz, a 10-fold improvement, vastly accelerating the return on investment for costly spectrum licenses.

Unparalleled Reliability & Flexibility

Availability in the “six-sigma” class, which is truly unique for electronic equipment. Because the HYPRES technology enables universal interoperability among legacy, current, and future wireless protocols, it enables an agile business model that can quickly adapt to meet changing market environments and rapidly accommodate new initiatives (such as spectrum sharing, etc). Our hardware will accommodate generations of software upgrades and changes.

Extended Mobile Battery Life

HYPRES base station products significantly extend the life of the battery of the mobile terminals. Transmit function consumes most of the power in a

user (mobile or stationary) terminal. The ultra high performance enabled by the HYPRES base station technology enables adequate link margin at a lower level of transmit power from the user units. And extends the time allowed for high data rate transmission from the mobile unit. In either case, this also allows longer times to recharge the battery.

A “Natural” for Distributed Radio (over fiber, etc.)

Our front ends operate at very high speeds, which is ideally suited for transmission on fiber or microwave for distributed access -- for both remote RF head or remote baseband (hotel) operation.

Future-Proof beyond 3G

Our inherent capability exceeds 30Mb/s plus all of the features/benefits cited above sum up to a truly future-proof product. HSDPA is inherent in the HYPRES Digital RF transceiver. This could be the last base station product that you will ever need.

The HYPRES **Digital-RF** (all digital) transceiver provides a single universal platform that can be configured dynamically and/or periodically to suit many different applications. The HYPRES **Digital-RF** transceiver reduces user operations complexity as a common design & common user interface can be provided for all functions across the various applications. Tera-Operations Digital Signal Processing (DSP) and quantum accuracy in the RF domain (RF DSP) provide unprecedented capacity to dynamically program:

- Operating frequencies & bandwidths
- Modulation & access techniques
- Noise, spurs & interference suppression techniques
- Acquisition & synchronization techniques
- Intelligent RF monitoring & control
- Adaptive sub-sectorization
- Balancing forward and reverse links
- RF switching & routing

HYPRES SME technology provides, for the first time, the ability to operate the RF domain in the digital world. The system degrading, hardware limited analog designs of the past are eliminated. The unique features of HYPRES SME technology that make these benefits possible are summarized below:

Unique Features of Superconductor Technology

- **Ultra-High Digital Logic Speed** **Single Flux Quantum (SFQ) logic is the world's fastest**
(Devices ~10X faster than semiconductor, LSI ~ 50X faster than semiconductor)
- **Ultra-Low Power Dissipation** **10,000X lower than semiconductor technology**
(Power dissipation for LSIC ~ 1 mW, Switching energy ~ 10^{-18} J)
- **Quantum Accuracy** **Defines the Volt**
(5ppb accuracy at 10V)
- **Fundamental Linearity using Magnetic Flux Quantization** **Very High-SFDR ADC and DAC**
(Conversion between analog and digital domains through flux quantum ($\Phi_0 = h/2e$) is independent of circuit parameters)
- **Extremely High Sensitivity** **SQUID (ADC front-end) is the most sensitive energy detector**
~60dB better than conventional semiconductor front end
(Example ~ -155dBm for 1 MHz BW, with slope of 20 dBm/decade)
- **Extremely Low Noise** **Receiver System Noise Temperature $T_S \sim T_A$**
(Thermal noise is essentially "0")
- **Ideal Interconnects** **Speed-of-light transmission in LSI circuits, no RC delay**
Low-impedance superconductor interconnects have negligible loss, dispersion and crosstalk
- **Simple, Inexpensive IC Fabrication** **Much less expensive complex chips and facilities/equipment to produce chips than semiconductors**
(~10 steps, no expensive operations, Thin Film)

Result: Digital-RF Technology

Unparalleled high-fidelity, wideband, high-sensitivity digital representation and subsequent processing ("RF DSP": channelization/correlation, spectrum control, broadband beamforming, and more...) of RF waveforms.

TECHNICAL SUMMARY

Ultrafast superconductor digital microelectronic circuits operate at speeds over 100 GHz, enabling true digital-RF architecture. This permits direct conversion between analog RF and digital baseband signals, replacing frequency and protocol-specific analog hardware with flexible, software-programmable digital processors. On the receive side, high sampling-speed (>20 Giga samples/s) and linearity (>100 dB spur-free dynamic range) of superconductor analog-to-digital converters (ADCs), digital down-converters and ultrafast (20 GHz) digital filters have already been demonstrated by HYPRES. This will enable broadband digitization of the incoming RF waveform directly, leading to true digital channelization under full software control. In addition, the lower receiver noise temperature enhances information capacity, even in interference-limited systems. Similarly, on the transmit side, a high sampling-speed and quantum-linear digital-to-analog converter (DAC) preceded by digital up-converters and digital filters provide the scheme for direct synthesis of a spectrally pure RF transmit waveform. Furthermore, the power of digital processing at RF allows direct digital predistortion of the transmit waveform for linearization of the entire power amplifier chain. In this paper, we will discuss the benefits to future wireless systems, in terms of expanded range of high-data-rate coverage, lower handset battery power, higher spectral efficiency and lower cost for multi-carrier base-stations.

1. INTRODUCTION

The ultimate goal of software-defined radio (SDR) is bringing the digital domain as close to the antenna as possible, on both the receive and transmit ends of the transceiver system. In the optimum configuration, the RF signal itself would be directly converted to digital, without the necessity of analog conversion to a lower IF or baseband signal before digital processing. Conventional data converters (ADCs and DACs) and digital circuits are not fast enough to accomplish this, but the unique features of superconducting electronic technology have recently been shown to lead to ultrafast circuits with the speed, linearity, and dynamic range that can make true digital-RF processing possible [1-3]. These superconducting circuits are integrated circuits (ICs) based on Josephson junctions and "rapid-single-flux-quantum logic" (RSFQ), where switching speeds up to 750 GHz have been

demonstrated in basic circuits, making this far faster than competing semiconductor technologies [4-6].

HYPRES has an in-house foundry for making state-of-the-art superconducting integrated circuits (ICs), and routinely fabricates ICs with thousands of gates. Recent system demonstrations using this technology include an oversampling ADC operating at 20 Gsamples/s, complete with an on-chip digital decimation filter [7]. This chip exhibited a spur-free dynamic range (SFDR) of greater than 100 dB. Although this performance is far less than the limit of what should be achievable with RSFQ circuits, it is already comparable to the best state-of-the-art semiconductor ADCs [8]. A slightly modified and improved version of this circuit can form the basis for direct digitization of the RF signal at the antenna in a software radio system.

These superconducting circuits require operation at cryogenic temperatures, typically at 4 to 5 K. This might seem to present a serious impediment to practical application of these circuits to wireless systems, as temperatures on this scale have traditionally been available only in laboratory environments using liquid helium. However, commercial cryocoolers (essentially low-temperature mechanical refrigerators) have recently become available that can maintain the needed cryogenic temperatures indefinitely, with only electric power and an air-cooled compressor needed. Similar cryocoolers, fielded in commercial base stations for cooling superconducting passive filters, have proven to be extremely reliable (with a projected MTBF in excess of 90 years [9]). HYPRES and others have recently demonstrated the superior performance of superconducting ICs in cryocooled systems [10,11]. Further improvements in size, price, and power of these cryocoolers will occur with the increased market for superconducting ICs in communications and other industries. While the cryogenic nature of these systems will be virtually invisible to the end-user, the low temperature makes a significant contribution in reducing the overall receiver noise temperature.

2. DIGITAL-RF TRANSCEIVER ARCHITECTURE

A block diagram of the digital-RF transceiver is shown in Fig. 1. In the receiver, the RF signal from the antenna is filtered and (possibly) amplified, but is then sent directly to a bandpass ADC, without first down-converting using an analog mixer and local oscillator. The down-conversion is carried out completely in the digital domain, in a way that can be easily reprogrammed. A digital decimation filter is used to decrease the output bandwidth, while increasing the effective number of bits. This is

likely to be a quadrature receiver, but the quadrature channel is left out of the figure for simplicity. There may also be channelization into multiple baseband channels, as described below. Finally, with only slight modifications, the receiver can be reconfigured as a correlation-based receiver, using a digitally-generated template and an appropriately matched digital filter.

The transmitter carries out the same digital functions in reverse, with a fast DAC reconstructing the RF signal directly, just before the high-power amplifier (HPA). The diagram also shows a dynamic digital equalizer, a predistortion module that is combined with the DAC to compensate for nonlinearities in the HPA. In principle, this predistortion module can be dynamically adjusted to account for memory and other effects in the HPA. Also, multiple channels can be combined digitally into one broadband digital-RF signal before amplification, so only a single HPA is necessary.

All fast digital and data conversion processes shown in Fig. 1 will be carried out using RSFQ low-temperature superconductor (LTS) circuits cooled to deep cryogenic temperatures ~ 4 K. The figure also suggests that analog filtering and amplification can be carried out at an intermediate cryogenic temperature (~ 60 K) in order to minimize thermal noise. This is compatible with commercial cryocoolers, which incorporate two or more temperature stages in their design.

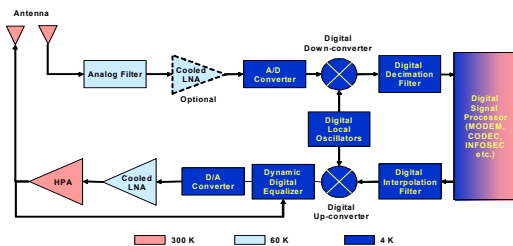

Fig. 1. Block diagram of conceptual digital-RF transceiver, where data conversion is carried out directly at RF frequencies, and signal extraction and processing are done using ultrafast superconducting digital electronic circuits (dark).

3. RECEIVER BENEFITS

Superconducting electronics exhibit unparalleled speed, accuracy and sensitivity. This unique combination of features can be harnessed to realize a true software-defined radio, where the whole frequency band-of-interest is digitized at RF with sufficient dynamic range and all subsequent signal processing is performed in the digital domain.

The realization of a true software-defined digital-RF receiver has been hindered by incremental (on an average 1.5 bits per 8 years [8]) improvements in conventional analog-to-digital

converter (ADC) technology. Quantum-accurate superconducting RSFQ (rapid single flux quantum) technology, through a unique confluence of desirable features, is the leading candidate to provide a leap in ADC performance, especially in terms of a high spurious-free dynamic range (SFDR) over a broad frequency band. Following digitization of the RF signal with a fast sampling clock (20-40 GHz at present, with the potential of well over 100 GHz with modest improvement in chip fabrication), the same ultra-fast RSFQ digital electronics process the ADC output, performing digital down-conversion and filtering. The major benefit of this architecture is the elimination of frequency- and protocol-specific, non-linear analog RF components. Superconducting digital-RF technology brings the fidelity, and flexibility of digital processing to the RF domain, enabling the receiver to be reconfigured in software.

The second major benefit of superconducting electronics comes from low noise and high sensitivity digitizer front-ends. The ADC front-end is the ultra-sensitive superconducting quantum interference device (SQUID), which is commonly used in most sensitive measurements of magnetic field and current. In many applications, the ADC front-end is sensitive enough to eliminate the need for the ubiquitous low-noise amplifier (LNA) in radio receivers. Since superconducting electronics operate at cryogenic temperatures (4-5 K), the thermal noise contribution is also reduced significantly compared to room-temperature receivers.

3.1. Digital-RF Processing

The RF band in a practical wireless communication system includes a large number of signals and several signal sub-bands. The greatest advantage of the digital-RF approach is obtained if the entire band is first digitized, with band separation and decoding carried out in parallel in the digital domain. Of course, this requires a wide-band bandpass ADC with extremely high dynamic range and low noise, combined with digital processing at multi-GHz rates. This is achievable using RSFQ superconducting electronics, and can lead to the development of a digital channelizer system, as shown in Fig. 2. In a digital channelizer system, the bandpass ADC modulator is followed by a bank of identical modular digital channelizer units. Each of these modules consists of a digital mixer (multiplier) with a programmable digital local oscillator for selecting band-location and a programmable digital filter for selecting bandwidth.

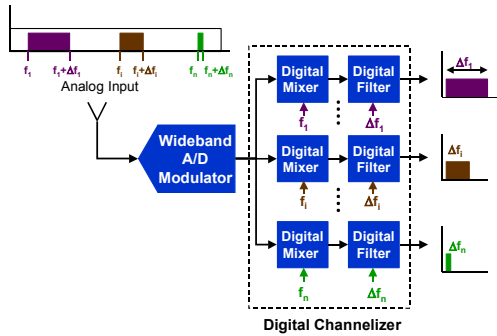

Fig. 2. Conceptual diagram of digital channelizer system, made feasible by a wideband superconducting ADC. Reconfiguration of the channels can be carried out under full software control.

These channelizer modules can be further generalized into correlation-based receivers. In a correlation-based receiver, the ADC modulator output is multiplied with a reference digital template, which may be much more complex than a periodic digital stream corresponding to a local oscillator. By synthesizing these digital templates, one can combine multiple functions, such as down-conversion, demodulation, despreading, and de-hopping, in one device. While digital cross-correlation is commonly used for direct spread CDMA, the ultra-fast superconducting electronics enables use of cross-correlation techniques directly on the sampled RF waveform, resulting in a digital-RF matched filter. This approach, where the radio is reconfigured by uploading the appropriate digital template, is also future-proof; any future waveform can be accommodated simply by synthesizing the corresponding template in software.

3.2. Low Noise

There is a widely held myth that improving receiver noise temperature does not benefit interference-limited systems, e.g. CDMA, where thermal noise power is designed to be a small fraction of the interference power from other users. That is not true. As will be shown below, lower receiver noise (N_0) can be used to improve different facets of a communication link: longer range, smaller transmitter power, higher data rate, and higher capacity. Lowering receiver noise temperature ($T_s = N_0/k_B$) allows interference power to drop proportionately, while maintaining the same interference-to-noise ratio. Consequently, the signal-to-interference-plus-noise-ratio (SINR) improves by the same factor as the reduction in T_s .

In a CDMA system, the bit-energy-to-noise-density ratio, $E_b/(N_0+I_0)$, is dominated by the interference power density (I_0), which is much larger than thermal noise power density (N_0) [12]. The interference power includes contribution from all other users in a cell, which are made nearly equal by active power control, as well as from users

in the neighboring cells. If we consider a CDMA cell with $M+1$ mobile users, sharing a spread spectrum bandwidth (W_{ss}) with a data rate R_b , and f is the relative interference factor from other cells, bit-energy-to-noise-density ratio for any one user can be expressed as

$$\frac{E_b}{N_0 + I_0} = \frac{\langle P_r \rangle / R_b}{N_0 + \frac{(1+f)}{W_{ss}} M \langle P_r \rangle}, \quad (1)$$

where $\langle P_r \rangle = \frac{1}{M} \sum_{m=1}^M P_{r,m}$ is the average received power from a user. The minimum bit-energy-to-noise-density ratio (R^*) required for the chosen modulation scheme determines the maximum number of users (M_{\max}),

$$M_{\max} = \frac{W_{ss}}{(1+f)R_b R^*}. \quad (2)$$

We can now rewrite equation (1) to calculate the minimum received power for each user to achieve the required R^*

$$R^* = \frac{\langle P_r \rangle_{\min} / R_b}{N_0 + \frac{1}{R_b R^* M_{\max}} M \langle P_r \rangle_{\min}}. \quad (3)$$

Rearranging the terms of equation (3), we obtain

$$\langle P_r \rangle_{\min} = \frac{N_0 R_b R^*}{1 - (M/M_{\max})}. \quad (4)$$

The benefits of a low-noise receiver can be seen by examining equation (4). First, the minimum required received power is directly proportional to the thermal noise power density (N_0). Therefore, the lower the receiver noise temperature ($T_s = N_0/k_B$), the lower is the required transmit power from each mobile user. Lowering the transmit power extends battery life and allows for longer periods of higher transmission rates.

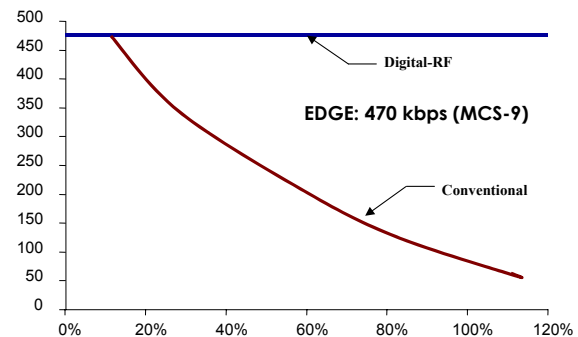

Fig. 3. Superconductor receiver expands the range of high data rate communications for cellular base stations.

Second, the data rate (R_b) is inversely proportional to N_0 . Therefore, the lower the receiver noise temperature, the higher is the permissible data rate, which is especially important for data

communication. Communication standards (e.g. cdma2000) allow a wide range of data rates, usually as multiples of a minimum data rate (e.g. 9600 bps). However, the maximum allowed data rate is usually available only within a limited region close to the base station. The available data rate drops sharply as the user moves away from the base station. The region of high data rate coverage can be expanded with a low noise receiver, ensuring better quality of service. Also, extension of the effective cell boundaries will facilitate soft-handoff in existing networks, resulting in better network optimization in terms of number of simultaneous users. Finally, the increased range of each base station may be utilized to reduce the number of base stations required to provide coverage in a region.

Third, R^* is also inversely proportional to N_0 . Lower receiver noise allows a higher R^* , which can be used to implement a higher symbol constellation to enhance the spectral efficiency. Higher R^* can also be used to lower bit error rate (BER) and raise quality of service.

Superconducting digital-RF receiver can lower the noise temperature of the receiver substantially. Consider a conventional receiver with a noise figure F_{RX} , connected to an antenna through a lossy cable. The receiver system noise temperature (T_S) referred to the antenna can be calculated by adding up the noise temperatures of the antenna (T_A), the cable (T_C) and the receiver (T_{RX}):

$$T_S = T_A + (L_C - 1)T_0 + L_C(F_{RX} - 1)T_0, \quad (5)$$

where T_0 is the ambient temperature (bandwidth ~ 1 GHz) receivers for military communication and electronic warfare (EW) systems.

On the other hand, the quantization noise of superconducting ADCs is very small. The noise temperature, which is a function of the ADC front-end bandwidth, is only 4 K and 40 K for bandwidths of 100 MHz and 1 GHz respectively for a 40 Gsample/s ADC. The system noise temperature (T_S) referred to the antenna in this case is

$$T_S = T_A + (L_C - 1)T_0 + L_C(L_D - 1)T_1 + L_C L_D (L_F - 1)T_1 + L_C L_D L_F T_{ADC} \quad (6)$$

where, L_D and L_F are the losses of high-temperature superconductor (HTS) diplexer and filter at a temperature $T_1 = 60$ K respectively, and the ADC is modeled as an unity gain device with a noise temperature T_{ADC} .

Table 1 lists the system noise temperature for various receiver configurations. Increasing the bandwidth of a receiver usually results in an elevated noise temperature. For a true software radio, the receiver must digitize a broad spectrum consisting of several narrower sub-bands, which are separated in the digital domain. Even if a

conventional receiver can perform the required wideband digitization, the noise temperature of the system will be prohibitively high. On the other hand, not only can superconductor technology enable the true software radio configuration, it also reduces noise temperature, compared to conventional narrowband receivers.

Receiver Type	T_{RX} (K)	T_S (K)
1.25 MHz Conventional	290 ($F_{RX} = 3$ dB)	1070 (G)
		515 (T)
100 MHz Conventional (Projected)	2000 ($F_{RX} = 9$ dB)	4500 (G)
		2300 (T)
100 MHz SME	4	520 (G)
		230 (T)
1 GHz Conventional	5500 ($F_{RX} = 13$ dB)	11500 (G)
1 GHz SME	40	605 (G)

Table 1: Comparison of system noise temperatures with conventional and SME receivers on ground (G) and tower (T)

4. TRANSMITTER BENEFITS

The same key features of the digital-RF receiver made possible by RSFQ superconducting electronics – wide bandwidth, high linearity, and high dynamic range – can be applied equally well to the development of a superconducting digital-RF transmitter. On the transmit side also, the waveform is processed completely in the digital domain up to RF before converting to analog with an ultra-linear RF digital-to-analog converter (DAC) [3].

Unlike the receiver, the transmitter must include a high-power amplifier (HPA). High-power amplifiers for RF transmitters inevitably exhibit significant nonlinearities, particularly when they are operated near their maximum output powers. This causes mixing of output components, leading to intermodulation distortion (IMD).

One can operate the HPA far below its saturation level, where it is more linear, but this is expensive, always energy-inefficient and may be impractical for some applications. Alternatively, if the output distortion of the amplifier is known, the input can be deliberately predistorted in a way that will cancel out the distortion in the output, linearizing the HPA. The two leading methods for HPA linearization are analog feedforward distortion compensation and digital predistortion [13,14]. Baseband predistorters rely on complicated digital signal processing algorithms working on the

demodulated low-frequency baseband digital waveform – *not the RF waveform* – in an attempt to compensate for the amplifiers non-linear gain and phase characteristics. These indirect methods involve either mapping an input in-phase and quadrature signal vector into an output signal vector or multiplying the signal with a level-dependent complex gain. These schemes require sophisticated, extensive DSP and the improvements have been gradual over the last two decades.

However, the circuit complexity is not the only drawback of such baseband digital predistortion schemes. The feedback delay involved in demodulating the HPA output back to baseband and then digitizing it to compare with the digital baseband data is too long (on the microsecond scale). This limits the effectiveness of the linearizer. On the other hand, analog feed-forward schemes perform distortion compensation directly on the RF waveform and do achieve better suppression of IMD. This scheme requires an additional active distortion cancellation loop, with a very linear second HPA and precise amplitude and phase matching of analog components. The analog feed-forward amplifiers are very expensive to manufacture and have very poor DC-to-RF efficiency compared to those using digital predistortion.

Unlike baseband or intermediate frequency (IF) predistorters [Fig. 4(a)], which are limited to narrowband correction of slowly varying nonlinearities, an RF predistorter can correct instantaneous, signal-dependent fluctuations of the HPA transfer function on a sub-nanosecond time scale. Only superconducting electronics is fast enough to perform RF predistortion in the digital domain [Fig. 4(b)].

High over-sampling ratios, possible with this technology, allow for corrections of higher-order harmonics of the RF waveforms, which is impossible in any other scheme. Therefore, unlike feed-forward schemes, the digital-RF predistorter can correct for strong nonlinearities (which leak out a significant fraction of the power into 3rd, 5th and higher harmonics), enabling the use of more power-efficient amplifiers (e.g. class AB). In other words, the digital-RF predistorters combine the advantages of digital predistortion – high efficiency, low cost, and high reliability – with those of analog feed-forward amplifiers – high degree of linearity and faster tracking of dynamic effects.

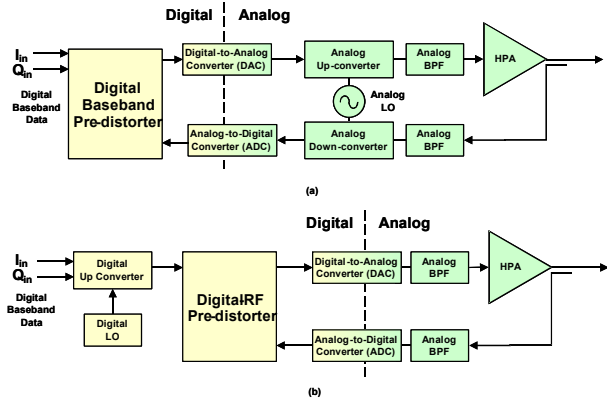

Fig. 4. (a) Digital baseband and (b) digital-RF predistortion schemes.

The combination of the ultra-linear RF DAC and the digital-RF predistorter enables spectrally-pure wideband transmit waveforms. Beyond the benefits of increased bandwidth and efficiency improvements, ultra-linear power amplifiers are becoming increasingly more important for both military and commercial wireless systems. Wideband systems, particularly multi-channel systems, will greatly benefit from the significantly reduced spurious signals, generated by the power amplifiers, which cause serious system-degrading interference. Also, the FCC has heightened interest in similar performance due to the developing spectrum utilization issues caused by increased wireless communication demand [15].

5. ADDITIONAL BENEFITS

There are a multitude of additional benefits too numerous to discuss in this paper, such as MUD, SIC, MIMO, Massively Time-Multiplexed Processing, Adaptive Antennas, Adaptive Sub-Sectorization, Dynamic Spectrum Management, which sum up to huge increases in range, capacity, and flexibility for GSM, CDMA, GPRS, EDGE, UMTS, and beyond. And last, but certainly not least, dramatic reductions in wireless network and base station electronics cost.

6. CONCLUSIONS

The ultimate performance of software radio systems requires digital processing and data conversion at multi-GHz rates, so that all key receiver components can be carried out under full software control. The only technology that can achieve this is superconducting digital-RF electronics. Using this technology, an entire RF band can be received and transmitted using the same RF antenna and amplifier. Processing of the individual channels can be carried out in parallel in the digital domain. Furthermore, since the superconducting receiver is so sensitive, major improvements can be obtained in

range, number of users, data rate and/or battery life. Finally, digital linearization techniques can be used to improve the efficiency and performance of high-power amplifiers in the transmitter.

HYPRES SME Technology Brings the Power of Digital Processing to the RF Domain and changes the Paradigm of Wireless Communications

7. ACKNOWLEDGMENT

The superconducting transceiver development project at HYPRES has been supported in part by development contracts from the U.S. DOD.

8. REFERENCES

- [1] D.K. Brock, E.K. Track, and J.M. Rowell, "Superconductor ICs: The 100 GHz Second Generation," *IEEE Spectrum*, December 2000, p. 40.
- [2] D.K. Brock, O.A. Mukhanov, and J. Rosa, "Superconductor Digital RF Development for Software Radio," *IEEE Communications Mag.*, February 2001, p. 174.
- [3] D.K. Brock, "Superconductor Microelectronics: A Digital RF Technology for Software Radios," Chapter 5 in *Software Defined Radio: Enabling Technologies*, ed. W. Tuttlebee, Wiley, England, 2002.
- [4] K.K. Likharev and V.K. Semenov, "RSFQ Logic/Memory Family: A New Josephson-Junction Digital Technology for Sub-Terahertz Clock-Frequency Digital Systems", *IEEE Trans. on Applied Superconductivity*, vol. 1, pp. 3-28, 1991.
- [5] W. Chen, A.V. Rylyakov, V. Patel, J.E. Lukens, and K.K. Likharev, "Rapid single flux quantum T-flip-flop operating at 770 GHz," *IEEE Trans. on Applied Superconductivity*, vol. 9, pp. 3212-3215, 1999.
- [6] D.K. Brock, "RSFQ Technology: Circuits and Systems," *International Journal of High Speed Electronics and Systems*, vol. 11, pp. 307-362, 2001. Also included in *High Speed Integrated Circuit Technology Toward 100 GHz Logic*, ed. M. Rodwell, World Scientific, Singapore, 2001.
- [7] O.A. Mukhanov, V.K. Semenov, I.V. Vernik, A.M. Kadin, T.V. Filippov, D. Gupta, D.K. Brock, I. Rochwarger, and Y.A. Polyakov, "High-Resolution ADC Operation up to 19.6 GHz Clock Frequency," *Superconductor Science and Technology*, vol. 14, pp. 1065-1070, 2001.
- [8] R.H. Walden, "Analog-to-digital converter survey and analysis," *IEEE Journal on Selected Areas in Communications*, vol. 17, no. 4, pp. 539-550, April 1999.
- [9] M. Hanes and A. O'baid, "Performance and Reliability Data for Production Free Piston Stirling Cryocooler," presented at the 12th International Cryocooler Conference, Cambridge, MA, USA, June 18-20, 2002; M. Hanes, "Performance and Reliability Improvements in a Low-Cost Stirling Cycle Cryocooler," *Cryocoolers 11*, ed. R. G. Ross, Jr. Kluwer Academic/Plenum Publishers, 2001.
- [10] Y.H. Tang, R.T. Hunt, R. Robertazzi, M.A. Fisher, J. Coughlin, R. Patt, E.K. Track, and E. Potenziani, "Cryocooled Primary Voltage Standard System," *IEEE Trans. on Instrumentation and Measurement*, vol. 46, pp. 256-259, 1997.
- [11] D. Gupta, A.M. Kadin, R.J. Webber, I. Rochwarger, D. Bryce, W.J. Hollander, Y.U. Kim, Channakeshav, R.P. Kraft, J.W. Kim, and J.F. McDonald, Proc. Applied Superconductivity Conference, Houston Texas, August 2002, to appear in *IEEE Trans. on Applied Superconductivity*, June 2003.
- [12] A.J. Viterbi, *CDMA Principles of Spread Spectrum Communication*, Addison Wesley, Massachusetts, 1995.
- [13] A. Katz, "Linearization: Reducing Distortion in Power Amplifiers," *IEEE Microwave Magazine*, pp. 37-49 (Dec. 2001).
- [14] P.B. Kennington, "Linearized Transmitters: An Enabling Technology for Software Defined Radio," *IEEE Communications Magazine*, vol. 40, pp. 156-162 (Feb. 2002).
- [15] FCC ET Docket No. 02-135 & Docket No. 03-237