

ZERO-IF AND NEAR-ZERO-IF QUADRATURE RECEIVERS FOR SDR

Jian Gu, 4D Connect, Inc., San Diego, California, USA. jian.gu@4dconnect.com

ABSTRACT

Zero Intermediate Frequency (ZIF) and Near Zero Intermediate frequency (NZIF) quadrature receivers are more sensitive to circuitry mismatch, which causes I-Q imbalance that may be frequency dependent over the signal bandwidth. An efficient and effective IQ-Balancing (IQB) technology has been developed to remove any adverse effect of the *frequency-dependent* I-Q imbalance. The IQB technology is based on the fact that any I-Q operations (ideal or non-ideal) can be modeled by an I-Q network that can be defined by a set of 2-by-2 matrices, each of which defines the imbalance condition at a given frequency. A quadrature receiver combined with the IQB technology is presented and the receiver can be used for ZIF/NZIF reception of any signals. Application examples for both wideband and narrow band signals are included to show how the quadrature receiver has much higher tolerance to I-Q imbalance in both ZIF and NZIF configurations.

1. INTRODUCTION

Receivers with Direct Conversion and Low-Intermediate-Frequency (Low-IF) radio architecture are attractive candidates for practical implementations of Software Defined Radio (SDR). Direct conversion and Low-IF are also called Zero Intermediate-Frequency (ZIF) and Near Zero Intermediate-Frequency (NZIF) conversions, respectively.

A ZIF receiver converts a received Radio Frequency (RF) signal directly into a complex low-pass equivalent or so-called base-band signal without any Intermediate Frequency (IF) stages as required by a super-heterodyne scheme. By using ZIF conversion, the radio/analog front end is largely simplified and many off-chip components such as Surface-Acoustic-Wave (SAW) filters can be eliminated so that higher level of integration for the radio/analog front end can be achieved. Therefore, it leads to implementation solutions with low power consumption, a low Bill of Material (BOM), small size, and high reliability. Because of its advantages, ZIF conversion is getting more and more attention [1].

NZIF receivers are attractive because they can also achieve high integration level and low cost implementation [2]. An NZIF receiver converts a received radio signal to an IF signal whose carrier frequency is in the order of the baseband signal bandwidth but is significantly lower than the radio carrier frequency. An NZIF radio architecture has some advantages over a ZIF scheme because it can avoid the DC offset and mixer self-mixing problems while being able to achieve high integration level and low cost implementation. It is especially useful for those base-band signals with significant component at or near DC. However, there is a need to suppress any unwanted adjacent channel signal in the image band of the wanted signal after NZIF conversion. Both ZIF and NZIF schemes use a quadrature demodulator or I-Q demodulator to convert the received radio signal into baseband signals or signals of bandwidth similar to that of the baseband signals.

A quadrature demodulator down-converts the received signal into a complex-number-valued representation—its real part as the in-phase component or I signal, and its imaginary part as the quadrature component or Q signal. Since the I and Q signals after down-conversion are usually weak and contaminated with interferences and noises, they must be amplified to a higher value, filtered free of interference and noise, and converted into digital signals by Analog-to-Digital Converters (ADCs). To do so, the demodulator needs down converters, amplifiers and filters in pairs for both I and Q signals. In order to preserve the same relative relationship between the original I and Q signals, these pairs are expected to match each other like identical twins.

However, in practical implementation, a quadrature demodulator may have a certain amount of mismatch between its down-converter, amplifier and filter pairs in its In-phase (I) and Quadrature (Q) channels. The mismatch is also called I-Q imbalance that includes gain, group delay and cutoff frequency difference of the two low-pass filters in the I and Q channels, and phase offset (over ideal 90 degrees) of the reference signals to the down-conversion mixer pair. Moreover, the I-Q imbalance may vary at any frequency within the baseband signal bandwidth, especially for reception of wideband signals with high order low pass filters and low-speed ADCs. The I-Q imbalance could largely compromise the

receiver performance. In some cases, the receiver could become dysfunctional due to the effect of the imbalance, especially for those signals with complicated high-density modulation schemes.

For ZIF and NZIF receivers, there are many amplification and filtering stages in both I and Q channels to meet sensitivity and interference performance, and, hence, the I-Q imbalance problem may become much more severe than any other radio architecture. Moreover, for an NZIF receiver, I-Q mismatch or imbalance will lead to poor adjacent channel interference or image rejection and cross-talks between the wanted signal and the adjacent channel signal/interference in the image band of the wanted signal.

IQ-Balancing (IQB) technology has been developed to overcome the adverse effect of I-Q imbalance [7]. With the IQB technology, any adverse effect of *frequency-dependent* I-Q imbalance of quadrature demodulators can be removed without additional analog circuits.

The paper first describes the IQB technology that is based on the fact that any I-Q operations (ideal or non-ideal) can be modeled by an I-Q network that can be defined by a set of 2-by-2 matrices, each of which defines the (imbalance) condition at a given frequency and if N is large enough for the interested frequency resolution.

The paper then shows how the IQB technology can be used with quadrature demodulators for ZIF/NZIF receivers for any modulation schemes to remove any adverse effect of I-Q imbalance.

Finally, the paper includes two examples to show how the IQB technology can make ZIF/NZIF receivers have much higher tolerance to I-Q imbalance. Fixed-point simulation results are included for a ZIF receiver for OFDM signals in Wireless LAN systems such as IEEE 802.11a and HiperLAN2 and for an NZIF receiver for signals in GSM system.

The remaining of the paper is organized as follows: Section 2 introduces IQ-Balancing (IQB) technology. Section 3 presents a quadrature receiver that is effective for ZIF and NZIF architecture under various I-Q imbalance conditions. Section 4 shows that the proposed quadrature receiver can be substantially immune from the I-Q imbalance by presenting some application examples in high speed Wireless Local Area Network (WLAN) and GSM systems. Section 5 concludes the paper.

2. I-Q IMBALANCE AND I-Q BALANCING

A typical quadrature demodulator is shown in Fig. 1, consisting of mixers, low-pass filters, and analog-to-digital converters (ADCs) in pairs, and, sometime, an analog complex filter that plays an important role in NZIF architecture. The mixer pair converts the received signal

into in-phase (I) and quadrature (Q) components. A pair of reference signals is also needed to the mixers and is

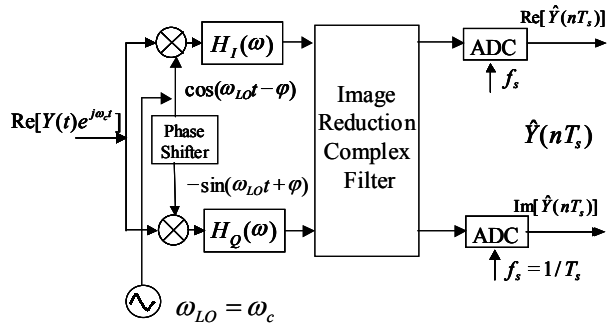

Fig. 1. A Quadrature Demodulator

expected to match in amplitude and in 90-degree phase difference ($\phi = 0$ in Fig. 1). The analog complex filter is used to suppress either negative or positive frequency components of the I-Q formatted signal or any portion of the frequency components of the signal over a range of negative frequency and positive frequency. It can be shown that any non-ideal implementation of the analog complex filter will also cause an equivalent effect of I-Q imbalance.

It can also be shown that the end result of any I-Q imbalance generates additional “cross-talk” between a component at a frequency and a component at the corresponding mirror frequency. For a single carrier signal with direct conversion or ZIF reception, the “cross-talk” reduces useful signal energy (by leakage) without distortion. However, when using ZIF reception for a multi-carrier signal, the “cross-talk” can cause severe interference between the sub-carriers at the mutual mirror frequencies. For any signal with NZIF reception, the “cross-talk” from an adjacent channel signal in the mirror or image band of a wanted signal always generates additional interference to the wanted signal. This additional interference can be disastrous since the interference is proportional to the level of the adjacent channel signal given I-Q imbalance conditions and can be stronger than the wanted signal.

I-Q Balancing (IQB) technique has been developed to remove the adverse effect of I-Q imbalance [7]. For any quadrature demodulators and, in general, any I-Q networks as shown in Fig. 2, we can decompose the time domain signal $\hat{Y}(t) = \sum_{k=-N}^N \hat{X}(k) \cdot \exp(j2\pi k \Delta_f t)$ over a certain duration (by FFT) into frequency components in frequency domain with equal frequency spacing and each pair of the components at mutual mirror frequencies can be represented in terms of the corresponding frequency components of the ideal imbalance-free signal

$Y(t) = \sum_{k=-N}^N X(k) \cdot \exp(j2\pi k \Delta_F t)$, where Δ_F is the frequency spacing between the components, by:

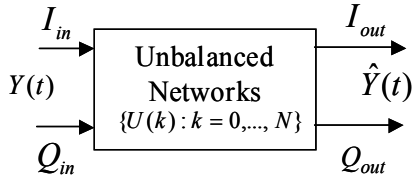

Fig. 2. An I-Q Network with Unbalanced Matrices

$$\begin{bmatrix} \hat{X}(k) \\ \hat{X}^*(-k) \end{bmatrix} = U(k) \begin{bmatrix} X(k) \\ X^*(-k) \end{bmatrix}, k=0, \dots, N, \quad (1)$$

where $U(k) = \begin{bmatrix} a_k & b_k \\ c_k & d_k \end{bmatrix}$. $\{\hat{X}(k) : |k| \leq N\}$ and $\{X(k) : |k| \leq N\}$ are the FFT coefficients of $\hat{Y}(t)$ and $Y(t)$, respectively, over the duration. The parameters a_k , b_k , c_k , and d_k are called *imbalance coefficients* and can be represented by $a_k = G_k + j \cdot g_k$, $b_k = \Delta_k + j \cdot \delta_k$, $c_k = \Delta_k - j \cdot \delta_k$, and $d_k = G_k - j \cdot g_k$, where the parameters G_k , g_k , Δ_k , and δ_k are, in general, complex numbers and, therefore, $a_k \neq d_k^*$ and $b_k \neq c_k^*$. These parameters can be explicitly represented in terms of the imbalance conditions of the I-Q network at frequency $k\Delta_F$ [7][8]. The 2-by-2 matrixes $\{U(k) : k = 0, \dots, N\}$ in (1) are called *imbalance matrixes*. As we can see, any two cascaded I-Q networks having their own matrixes similar to (1) can be represented by one set of equations similar to those in (1). In [8], it is shown that the equations of (1) can fully define any linear I-Q network shown in Fig. 2 as long as N is large enough to provide sufficient frequency resolution.

There are many ways to obtain the imbalance coefficients or related coefficients, based on which the inverse matrix can be derived. The simplest way to obtain the coefficients or the ratios of the coefficients is by sending some known training signals (such as sine wave tones at the corresponding frequencies) locally or remotely to the quadrature receiver [7]. Then, $X(k)$ and $X(-k)$ can be recovered from $\hat{X}(k)$ and $\hat{X}(-k)$ up to some complex constant scales for given k by a basic balancing block shown in Fig. 3. More details can be found in [7]. Other methods include decision feedback and pilot symbol-aid adaptation, etc.

There is a little problem with the parameters at DC ($k=0$). According to [7], two training tones of 90 degrees phase difference are needed to obtain the imbalance coefficients at DC. However, this may not be feasible if an ideal local modulator or phase shifter is unavailable.

An alternative approach to get around this is to represent the distorted signal and the I-Q imbalance-free

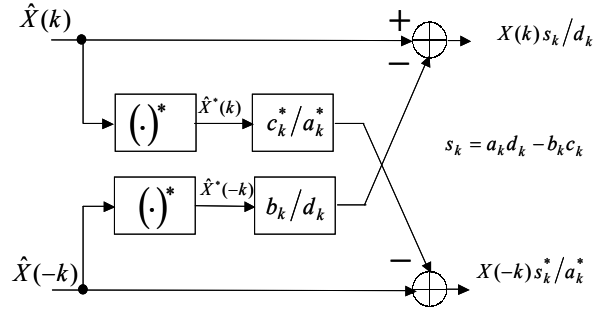

Fig. 3. A Basic Balancing Block

signal by $\hat{Y}(t) = \sum_{k=-N+1}^N \hat{X}(k-0.5) \cdot \exp(j2\pi(k-0.5)\Delta_F t)$ and $Y(t) = \sum_{k=-N+1}^N X(k-0.5) \cdot \exp(j2\pi(k-0.5)\Delta_F t)$, respectively, where the arguments of $\hat{X}(\cdot)$ and $X(\cdot)$ are simply labels for the corresponding frequency components. All the derivations in [7] and [8] are still valid and, similarly to (1), there are:

$$\begin{bmatrix} \hat{X}(k-0.5) \\ \hat{X}^*(-k+0.5) \end{bmatrix} = U(k) \begin{bmatrix} X(k-0.5) \\ X^*(-k+0.5) \end{bmatrix}, k=1, \dots, N, \quad (2)$$

Then, $X(k-0.5)$ and $X(-k+0.5)$ can be recovered from $\hat{X}(k-0.5)$ and $\hat{X}(-k+0.5)$ up to some complex constant scales for given k by a Basic Balancing Block similar to the one shown in Fig. 3 by replacing k with $k-0.5$. Note that now the parameters a_k , b_k , c_k , and d_k are related to the imbalance conditions of the I-Q network at frequency $(k-0.5)\Delta_F$, for $k=1, \dots, N$. We call this approach IQB with Frequency Shifting or IQB-FS.

3. ZIF/NZIF QUADRATURE DEMODULATOR WITH IQB TECHNOLOGY

A ZIF/NZIF quadrature demodulator is shown in Fig. 4, which consists of a conventional quadrature demodulator, an analog complex filter and a Digital IQB Unit. The IQB Unit removes the adverse effect of I-Q imbalance by digital processing techniques that can be implemented by digital logic circuits or DSP. When the quadrature demodulator is used as an NZIF demodulator, the input baseband signal $Y(t) = Z(t)\exp(j\omega_{IF}t)$ where $Z(t)$ is the baseband signal of interest, ω_{IF} is the angular IF frequency, and the output of the quadrature demodulator after ADC is supposed to be $Y(nT_s) = Z(nT_s)\exp(j\omega_{IF}nT_s)$ (Assume that the IF sits in the positive frequency band after down-conversion for

convenience.). To obtain $Z(nT_s)$ from $Y(nT_s)$ is an easy task for the following digital processor. The demodulator can also be configured as a ZIF demodulator by setting the IF frequency to zero. When there is any I-Q imbalance,

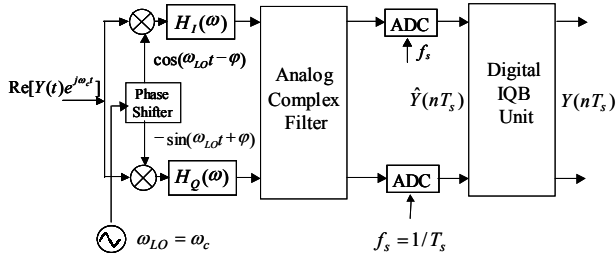

Fig. 4. A Quadrature Demodulator with an IQB Unit

the sampled signal after ADC is $\hat{Y}(nT_s)$.

The analog complex filter in Fig. 4 is used to suppress a strong interference in the image band of the wanted signal for when used with an NZIF receiver. With the IQB technique, the complex filter can be used only for the cases where the following Analog-to-Digital Converters (ADCs) have insufficient dynamic range for the interference or the unwanted interference level is substantially higher than the wanted signal.

The complex filter can be an active or passive (asymmetrical) poly-phase filter designed to suppress only portion of frequency components such as negative frequency components [2][3][4]. While a complex filter can performs its expected function in ideal conditions, it *does* introduce additional cross-talk to the wanted signal under mismatch conditions which can be viewed equivalently as I-Q imbalance at some frequencies. The center frequency of the complex filter is usually at about ω_{IF} . However, if the center frequency of the filter is tunable and can be set to zero frequency, the NZIF demodulator may become a ZIF demodulator.

A first-order (asymmetrical) poly-phase filter is shown in Fig. 5. Its transfer function is resulted from frequency translation of a low pass filter $H(j\omega) = \frac{1}{1 + j\omega/\omega_o}$ to $H(j(\omega - \omega_c)) = \frac{1}{1 + j(\omega - \omega_c)/\omega_o}$ where ω_o is the 3 dB bandwidth of the low-pass filter and ω_c is the center frequency of the poly-phase (band-pass) filter. The mismatch of the coefficients in Fig. 5 will affect pole positions and I-Q channel gain mismatch in the frequency band of interest. By setting its crossover coefficients to zeros, the filter has a center frequency 0, which becomes a complex low-pass filter consisting of two independent real-valued filters.

A Digital IQB Unit in Fig. 4 is further detailed in Fig. 6. When a new set of M samples of $\hat{Y}(t)$ is stored in the

sample buffer, the samples are processed by the FFT, I-Q balancing, optional frequency domain filtering, and IFFT blocks. The I-Q balancing block consists of $M/2$ Basic Balancing Blocks as shown in Fig. 3. At the output of the

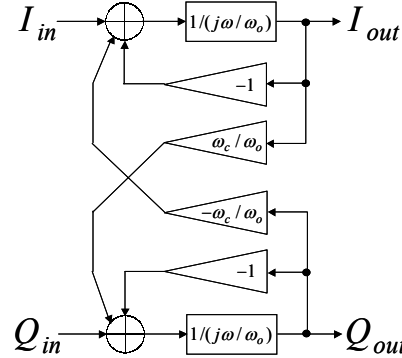

Fig. 5. A First Order Poly-Phase Filter

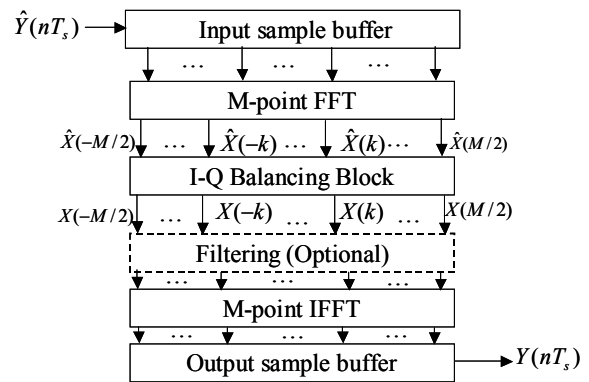

Fig. 6. Digital IQB Unit

Digital IQB Unit, the samples of $Y(t)$ are recovered from the samples of $\hat{Y}(t)$ after removal of the I-Q imbalance effect. Any other following blocks such as equalization and decoding can further process the resulting imbalance-free signal.

We use FFT to convert the time domain signal samples into frequency components according to $\hat{X}(k) = \sum_{n=0}^{M-1} \hat{Y}(nT_s) \cdot \exp(-j2\pi nk/M)$ and then apply the IQB technology to them. The frequency spacing between the components is f_s/M , where f_s is the sampling frequency of ADC in Fig. 4 and M is the size of the FFT and IFFT operations inside the Digital IQB Unit. $\{(\hat{X}((M-k)\%M), \hat{X}(k)): \text{for } k=0, \dots, M/2-1\}$ are the input pairs of the $M/2$ Basic Balancing Blocks, where “ $\%M$ ” stands for modulo M operation. After the IQ-Balancing Block, the resulting frequency domain samples are then

converted back to time domain samples by IFFT and the resulting time domain samples are substantially I-Q imbalance free if the frequency spacing f_s / M is small enough to resolve the I-Q imbalance in frequency domain. (Note: If the quadrature demodulator is ideal, then the

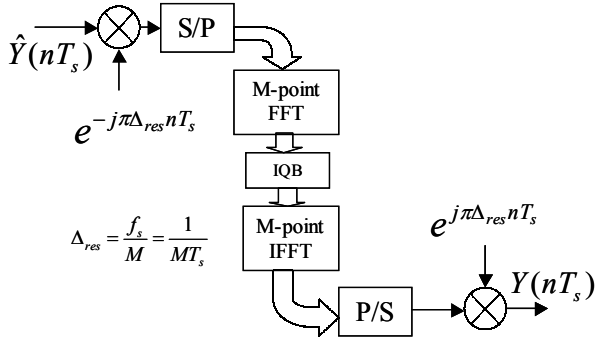

Fig. 7. Digital IQB Unit with Frequency Shifting

cross-over coefficients in the Basic Balancing Block of Fig. 3 are essentially zeros and the FFT and IFFT operations of any size M make no changes to the original signal samples.) Filtering or equalization in frequency domain if needed is an easy task after the IQB operation and before the IFFT operation. The coefficients that are needed during the operation of IQB can be obtained by sending some training tones to the receiver [7]. The training tone spacing should be the same as the frequency spacing. For NZIF receivers, the frequencies of the training tones need only cover the negative frequency band, which is usually the mirror band of the wanted signal after the down-conversion.

Fig. 7 shows a Digital IQB Unit using the aforementioned alternative IQB approach – IQB-FS. The S/P (serial-to-parallel) and P/S (parallel-to-serial) conversion blocks are also sample buffers. Before the FFT operation the input samples’ frequency is offset by $0.5 \cdot f_s / M$ which is half of the component frequency spacing. And after the IFFT operation, the output samples are then rotated back to the original frequency. These frequency conversions are necessary in order to use FFT and IFFT operations to implement the IQB-FS approach, as described by equations (2). Note that now in the IQB operation, $\{(\hat{X}((M - k + 1)\%M), \hat{X}(k)) : k=1, \dots, M/2\}$ are the pairs at the input of the $M/2$ Basic Balancing Blocks. The frequencies of the training tones should also be shifted by $0.5 \cdot f_s / M$ accordingly.

Note that with IQB-FS, the DC component of $\hat{Y}(nT_s)$ is not orthogonal to all “sub-carriers”, meaning that the DC component will spread to all “sub-carriers” and that this is useful information for DC nullifying. If the baseband signal has DC or near DC frequency

component of interests, then the IQB-FS approach should be used for ZIF receivers.

The IQB technology can also be applied to ZIF/NZIF quadrature modulator/transmitter [7], leading to very simple implementation. For example, a simple RC network can be used to generate the reference LO signals to the up-conversion mixers of the I-Q modulator. The IQB technology can also be very valuable when highly accurate I-Q modulators are needed to generate signals, such as using I-Q modulators to generate two phase-modulated signals for the two branches of an ELINC system [9].

4. APPLICATION EXAMPLES

In this section, we will present some application examples of the quadrature receiver described in Fig. 4 to demonstrate how the IQ-Balancing (IQB) technology can enhance the performance of quadrature demodulators against I-Q imbalance.

4.1. ZIF Reception of OFDM Signals

First, we will present an application example of the quadrature receiver with the IQB technology in high speed WLAN systems such as IEEE 802.11a [5] and HiperLAN2 [6].

IEEE 802.11a and HiperLAN2 are two WLAN standards supporting a data rate up to 54 Mbits/second over a 20 MHz radio channel in the 5 GHz ISM band for wireless data access applications. The two standards have a similar physical layer and use OFDM as their modulation scheme. In both standards, the OFDM modulated signal consists of 53 sub-carriers spaced 312.5 kHz among which are 48 data sub-carriers, 4 pilot sub-carriers, and the center sub-carrier that is not used. Each data sub-carrier is modulated by an independent data source, using different digital modulation schemes (such as BPSK, QPSK, 16-QAM and 64-QAM) depending on the data rate. The symbol rate of each sub-carrier is 250 kilo-bauds per second corresponding to symbol duration of 4 μ s. The resulting OFDM signal has an aggregate data rate of 54 Mbits/second when 64-QAM is used for each data sub-carrier and occupies a radio frequency bandwidth of about 16.6 MHz.

When a ZIF receiver is used for this wide-band signal, I-Q imbalance becomes a critical issue, especially when a denser constellation is used for each data sub-carrier. Moreover, if a minimal sampling frequency (For example, 20 Mega Samples Per Second for the aforementioned OFDM signals) of Analog-to-Digital (ADC) is used, the low-pass filters in Fig. 1 are not only for anti-aliasing filtering but also for adjacent channel

interference rejection, since there is no effective digital filtering to reject adjacent channel interference whose carrier frequency is at 20 MHz away from the carrier of the wanted signal. In such a scenario, the low-pass filters need to be of high order with steep frequency response in their transition band. For example, the low-pass filters may be

Table 1: Sensitivity Performance Requirement

Data Rate / Modulation	IEEE 802.11a	HiperLAN2
6 Mbps/BPSK	-82 dBm	-85 dBm
9 Mbps/BPSK	-81 dBm	-83 dBm
12 Mbps/QPSK	-79 dBm	-81 dBm
18 Mbps/QPSK	-77 dBm	-79 dBm
24 Mbps/16QAM	-74 dBm	N/A
27 Mbps/16QAM	N/A	-75 dBm
36 Mbps/16QAM	-70 dBm	-73 dBm
48 Mbps/64QAM	-66 dBm	N/A
54 Mbps/64QAM	-65 dBm	-68 dBm

Note: Measured signal level should be lower than the reference sensitivity level in the table to achieve Packet Error Rate <10%.

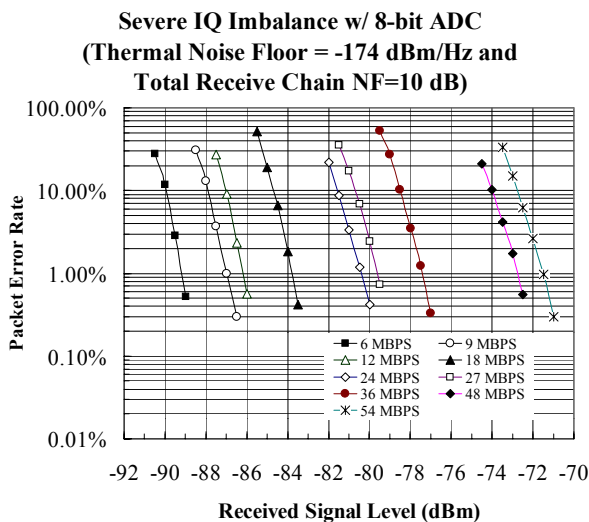

Fig. 8. Sensitivity Performance

5-th order Elliptic filters of 3-dB bandwidth about 9 MHz, with the transition band less than 2 MHz and ultimate out-of-band rejection 50 dB.

Table 1 includes the minimum requirement for sensitivity performance for IEEE 802.11a and HiperLAN2 systems at different data rates – i. e., given a data rate, the measured signal level should be less than the corresponding entry (Called reference sensitivity level) in the table in order to achieve less than 10% of Packet-

Error-Rate (PER). The sensitivity performance of the quadrature receiver has been evaluated by a fixed-point simulation system with major simulation conditions as follows:

- 1) Total receive chain noise figure is assumed 10 dB. Thermal noise floor is -174 dBm/Hz or -101 dBm/20MHz.
- 2) I-Q imbalance conditions: 10 degrees of I-Q phase offset, 3 dB of I-Q gain imbalance, 10% of 3 dB bandwidth difference between the I and Q low-pass filters. The low-pass filters are 5-th order elliptic filters of 3 dB bandwidth about 9 MHz.
- 3) 8-bit ADCs of sampling frequency 20 Msps are used, with all fixed-point algorithms including channel estimation, equalization, QAM demodulation, and convolutional code decoding using 4-bit soft decision variables for the Viterbi algorithm.

Fig. 8 shows the simulation results of the quadrature receiver performance with the IQB technology under the given simulation conditions and with the FFT/IFFT size $M=64$ for the IQB Unit. Note that the FFT/IFFT operations in the IQB unit have no relation in timing with the FFT operation of the OFDM demodulation. Major conclusions are summarized as follows:

- With IQB technology, the PER performances have no statistically difference from those under ideal I-Q conditions;
- Without using IQB technology, PER =100% for those data modes using 64QAM, which cannot be reduced by increasing signal power level.
- Without using IQB technology, PER performance is degraded by more than 10 dB for those data modes using 16QAM.

The above results show the effectiveness of the quadrature receiver against I-Q imbalance, especially, when the high-density modulation scheme is used. However, one may have questions about effectiveness of the quadrature receiver for simple modulation schemes such as binary modulation schemes. Now, let's look at the following application example of an NZIF quadrature receiver with IQB technology for the binary Gaussian Minimum Shift Keying (GMSK) modulated signal in GSM system.

4.2. NZIF Reception for GSM Signals

Recall that in the GSM system the bit rate is about 271 kbits/s and the channel spacing is 200 kHz. Choose 200 KHz as the IF frequency. The received signal including adjacent channel interference is over-sampled in 8 samples per symbol, which results in about $f_s = 2.17$ Msps. 8-bit ADC is used. $M=64$ is size of FFT/IFFT operations in the Digital IQB Unit. The wanted

GSM signal is received through a fading channel TU50. The interfering signal is 30 dB stronger than the wanted signal and its carrier frequency is set at the image frequency band of the wanted signal after down-conversion (i.e., 400 kHz below the radio carrier frequency of the wanted signal). A first-order poly-phase filter of center frequency 200 KHz and 3 dB bandwidth 100 KHz (single sided) is used.

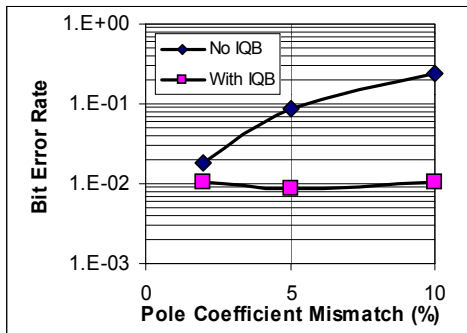

Fig. 9. Performance in Terms of Pole Coefficients

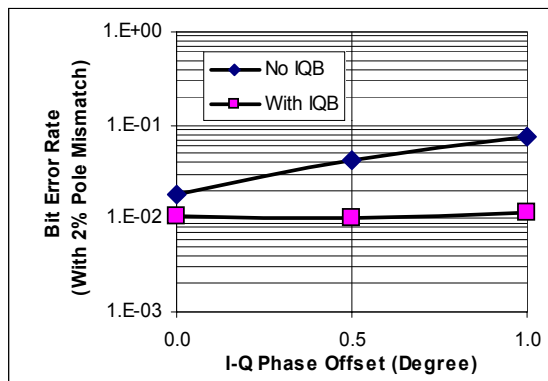

Fig. 10. Performance in Terms of I-Q Phase offset with 2% of Pole Mismatch

Fig. 9 shows the simulation results of the performance degradations in terms of pole coefficient mismatch up to 10% for the cases without IQB and with IQB. Fig. 10 shows the performance comparison between the cases without and with IQB as a function of different I-Q phase offset up to 1 degree (Equivalent to $\varphi = 0.5$ degree in Fig. 1) while the pole coefficients have a mismatch of 2%.

As we can see, for an NZIF receiver receiving simple binary modulated signals, the performance degradation can be significant without IQB, even with a small amount of I-Q imbalance. With the IQB technology, the receiver performance under severe I-Q imbalance conditions is less than 0.25 dB inferior to that under ideal I-Q conditions.

4.3. IQB Performance in Terms of FFT Size

It is desirable to know the performance of the IQB unit in terms of the implementation complexity. Therefore, we want to evaluate the IQB unit performance loss in terms of FFT size M . To do so, the fixed-point OFDM simulation system of IEEE 802.11a is used in the evaluation. The 54 Mbits/s mode with 64 QAM is used for

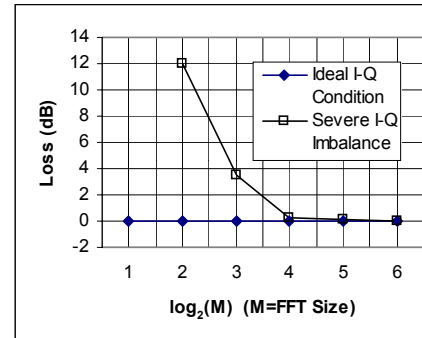

Fig. 11. Performance Loss in Terms of FFT Size of IQB

each sub-carrier of the OFDM signal with the severe I-Q imbalance conditions: 10 degrees of I-Q phase offset (over the ideal 90 degree condition), 3 dB of gain imbalance, and 10% of 3-dB bandwidth difference around 9 MHz. The IQB-FS approach is used with ZIF configuration.

Fig. 11 shows the simulation results by a curve of system PER performance loss near the reference sensitivity level in terms of FFT size M for the IQB Unit. As we can see, the IQB unit demonstrates a robust performance against severe I-Q imbalance and has less than 0.2 dB loss at $M=16$. It is obvious that under ideal I-Q conditions, there is no loss for any FFT size M . Therefore, it is expected that smaller M can also achieve small loss for less severe I-Q imbalance conditions.

5. CONCLUSIONS

ZIF receivers have many advantages in achieving low cost and small size solutions. NZIF receivers are attractive because they can avoid the DC offset and mixer self-mixing problems while achieve high integration level and low cost implementation. They are suitable to multi-band/multi-mode communications devices and are favorable options for a practical implementation of Software Defined Radio.

However, both ZIF and NZIF receivers are sensitive to I-Q imbalance, especially for complicated modulation schemes. For an NZIF receiver, there is a need to suppress the unwanted adjacent channel signal in the

image band of the wanted signal, which makes the NZIF receiver even more sensitive to I-Q imbalance than a ZIF receiver.

To overcome the adverse effect of the I-Q imbalance, IQ-Balancing (IQB) technology has been developed, which is based on the fact that any I-Q operations (ideal or non-ideal) can be modeled by an I-Q network that can be defined by a set of 2-by-2 matrices, each of which defines the imbalance condition at a given frequency. By applying the IQB technology to a quadrature demodulator, the resulting quadrature receiver can have high tolerance to any I-Q imbalance.

Two application examples are provided. The first example shows that the quadrature receiver with the IQB technology can be used to form an effective ZIF receiver that has much higher tolerance to I-Q imbalances for high speed WLAN systems such as IEEE 802.11a and HiperLAN2. The fixed-point simulation results show that the resulting ZIF receiver can have achieve significant performance improvement under severe I-Q imbalance conditions, especially, when the OFDM signals are in the high-speed data modes with higher density modulation schemes.

The second example demonstrates that the quadrature receiver can also be very effective when used with NZIF architecture for simple binary modulation schemes like GMSK modulation. Fixed-point simulation results show that the Bit-Error-Rate (BER) performance of an NZIF receiver can degrade significantly even under a small amount of I-Q imbalance when not equipped with IQB. However, with the IQB technology, an NZIF receiver can tolerate severe I-Q imbalance conditions.

It is also shown that the implementation of the IQB technology can be very simple and effective by using FFT and IFFT operations even for complicated OFDM signals with 64QAM under severe I-Q imbalance conditions and that the implementation can be even simpler for less severe I-Q imbalance conditions as long as the Digital IQB Unit can resolve the frequency-dependent I-Q imbalance.

The IQB technology can also be used with ZIF/NZIF quadrature modulators/transmitters, resulting in high accuracy modulation with simple radio architecture.

With the IQB technology, ZIF and NZIF quadrature receivers will no longer suffer from I-Q imbalance and, therefore, become more favorable and feasible solutions to low-cost radio front-end for SDR.

6. REFERENCES

- [1] A.A. Abidi, "Direct-Conversion Radio Transceivers for Digital Communications," *IEEE J. Solid-State Circuits*, vol. 30, no. 12, pp.1399-1410, Dec. 1995.
- [2] J. Crols and M.S. J. Steyaert, "Low-IF Topologies for High-Performance Analog Front Ends of Fully Integrated Receivers," *IEEE Trans. on Circuits and Systems –II: Analog and Digital Signal Processing*, vol. 45, No. 3, pp. 269-282, March 1998.
- [3] J. Crols and M. Steyaert, "An Analog Integrated Polyphase Filter for a High Performance Low-IF Receiver," 1995 Symposium on VLSI Circuits Digest of Technical Papers, pp. 87-88, June 1995.
- [4] M. J. Gingell, "Single sideband modulation using sequence asymmetric polyphase networks," *Electrical Commun.* vol. 48, pp21-25, 1973.
- [5] IEEE 802.11a, Part 11: Wireless LAN Medium Access Control (MAC) Specifications High-speed Physical Layer in the 5 GHz Band, 1999.
- [6] ETSI TS 101 475, (BRAN); HIPERLAN Type 2; Physical (PHY) layer, April 2000.
- [7] J. Gu. "Method and Apparatus to Remove Effects of I-Q Imbalances of Quadrature Modulators and Demodulators in a Multi-Carrier System," US patent application, PCT publication number: WO 02/056523.
- [8] J. Gu, "Zero-IF and Near Zero-IF Quadrature Demodulators with High Tolerance to I-Q Imbalance," *Proceedings of the International Conference of Asia Pacific Optical and Wireless Communications (APOC2002)*, October 14-18, 2002, Shanghai, China.
- [9] J. Gu, "An Enhanced Linear Amplification with Non-linear Component (ELINC) System," *Proceedings of the 2002 Radio and Wireless Conference (RAWCON2002)*, August 11-14, 2002, Boston, USA.